

ALÜMİNYUM BAZA TEZGAH PROFİLLERİ

1

Aluminium Plinth Worktop Profiles

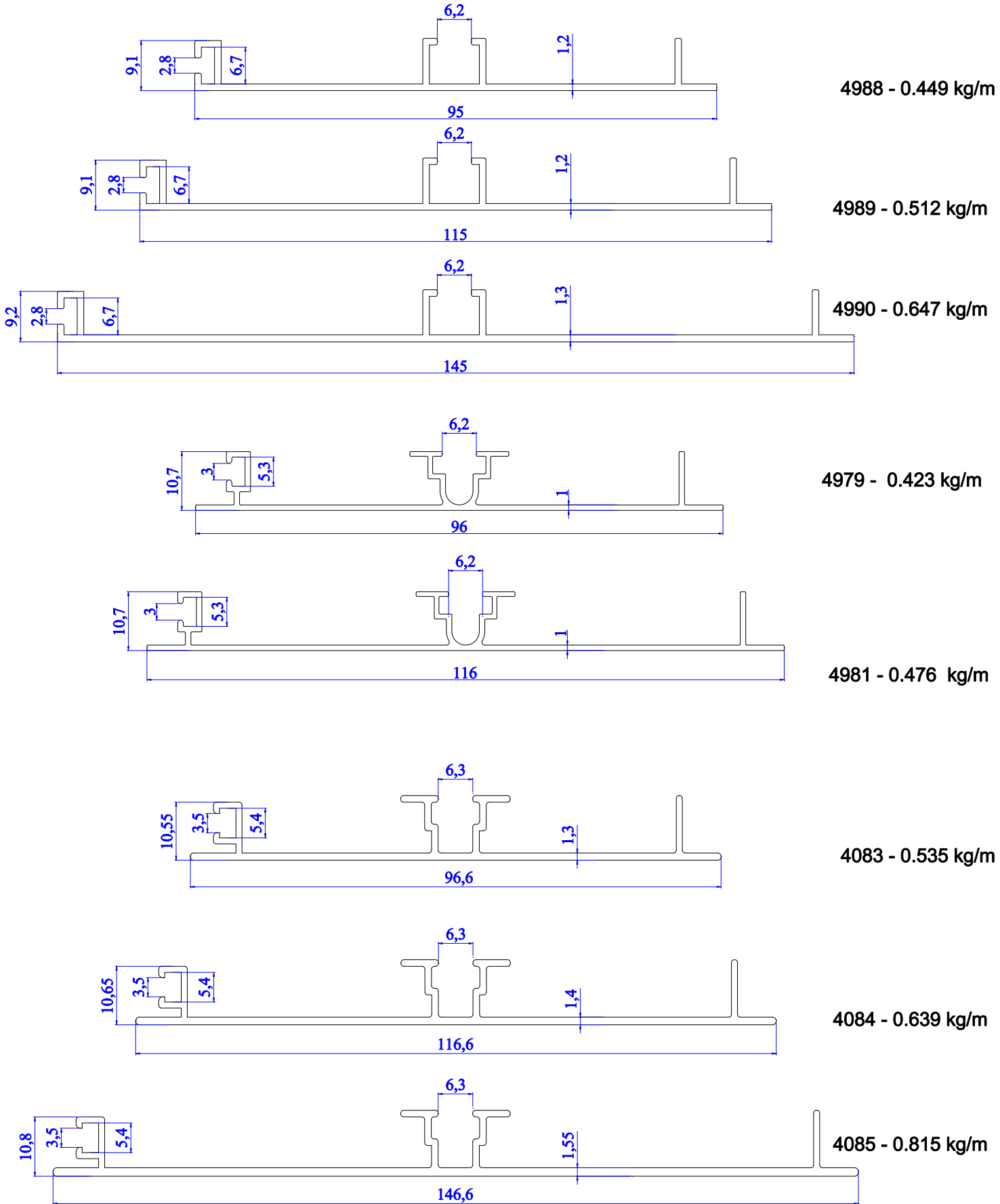

ALÜMİNYUM BAZA TEZGAH PROFİLLERİ

Aluminium Plinth Worktop Profiles

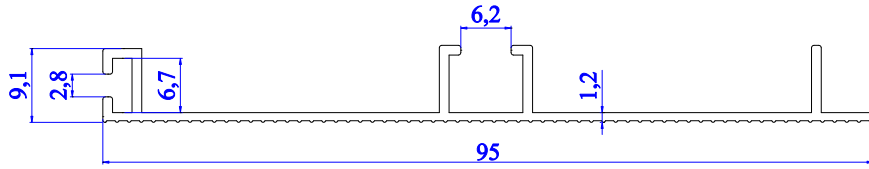

4985 - 0.409 kg/m

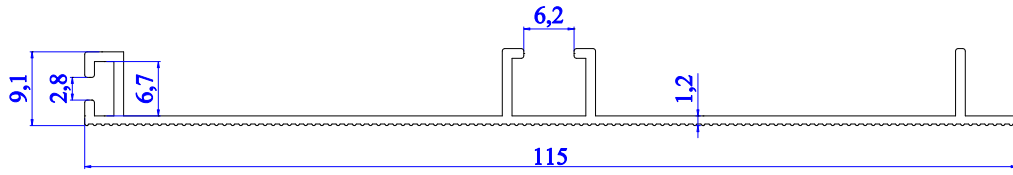

4986 - 0.471 kg/m

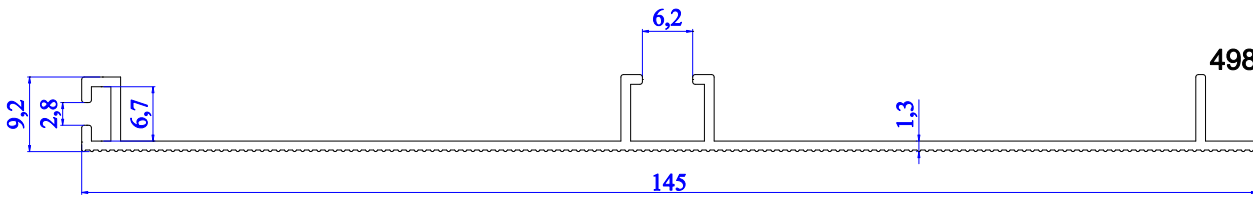

4987 - 0.595 kg/m

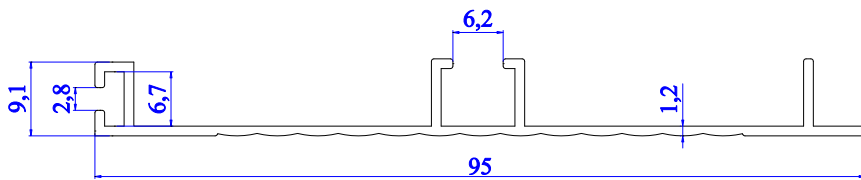

4991 - 0.430 kg/m

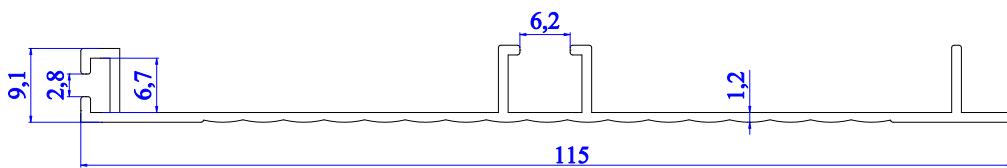

4992 - 0.489 kg/m

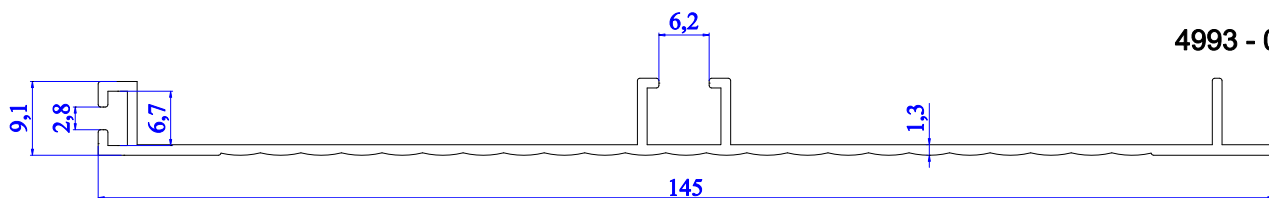

4993 - 0.615 kg/m

ALÜMİNYUM BAZA TEZGAH PROFİLLERİ

Aluminium Plinth Worktop Profiles

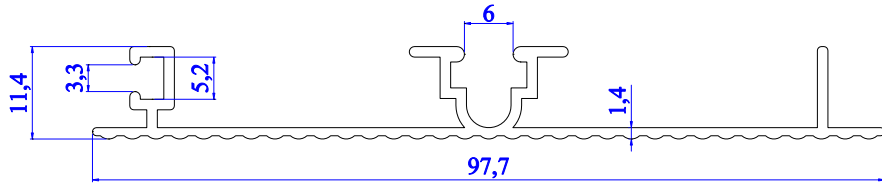

3933 - 0.548 kg/m

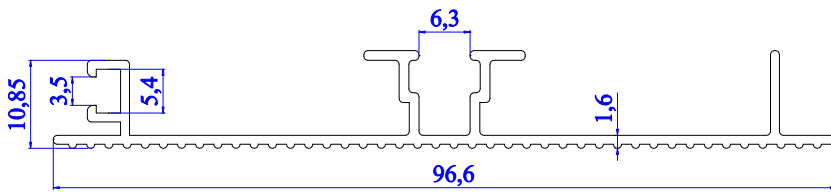

4080 - 0.530 kg/m

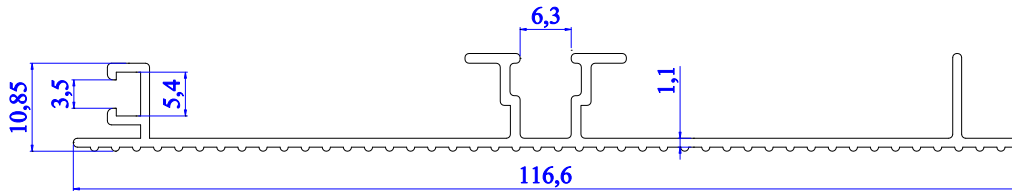

4081 - 0.592 kg/m

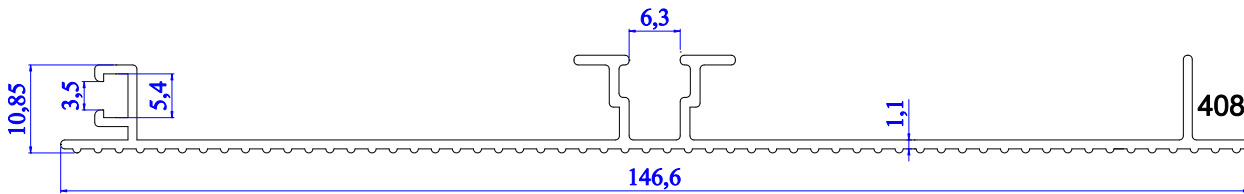

4082 - 0.693 kg/m

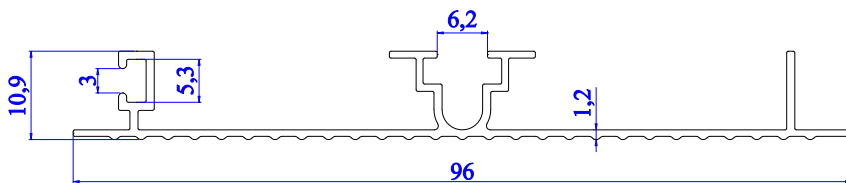

4980 - 0.398kg/m

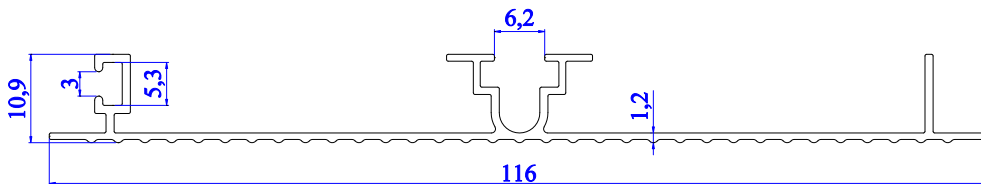

4982 - 0.445 kg/m

ALÜMİNYUM BAZA TEZGAH PROFİLLERİ

Aluminium Plinth Worktop Profiles

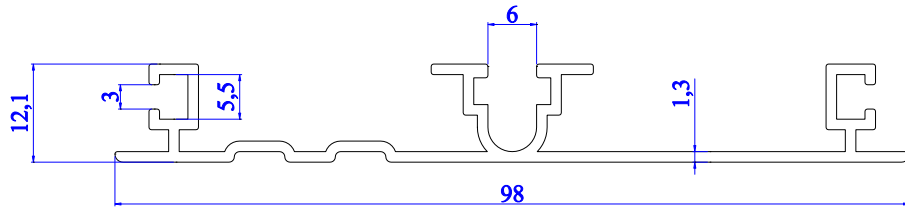

4039 - 0.652 kg/m

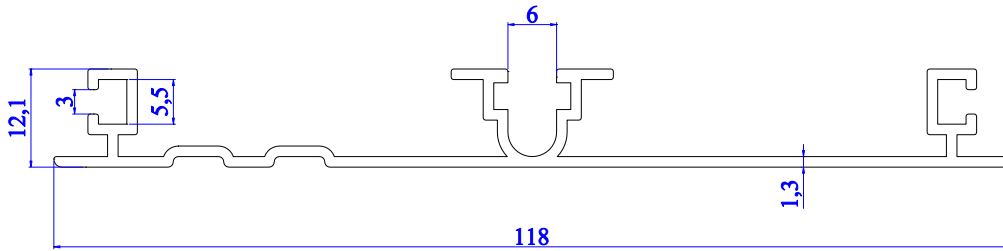

4040 - 0.722 kg/m

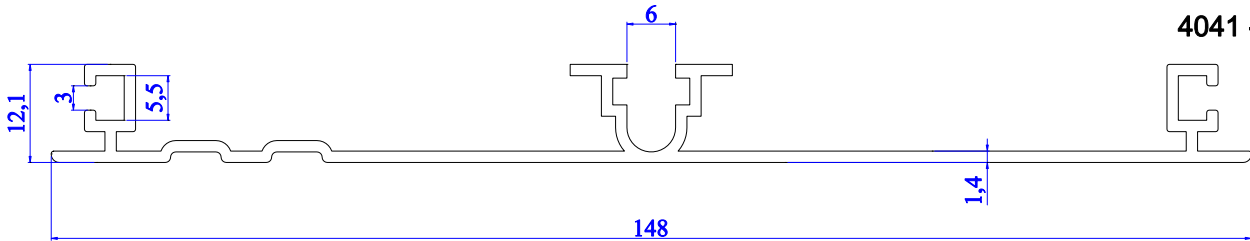

4041 - 0.889 kg/m

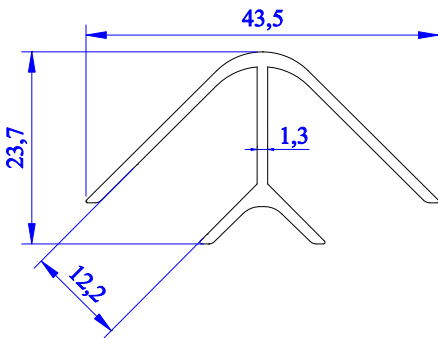

4031 - 0.338 kg/m

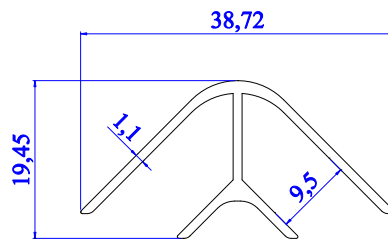

5137 - 0.256 kg/m

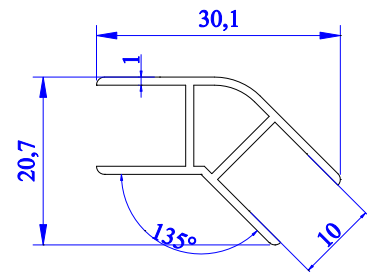

4295 - 0.217 kg/m

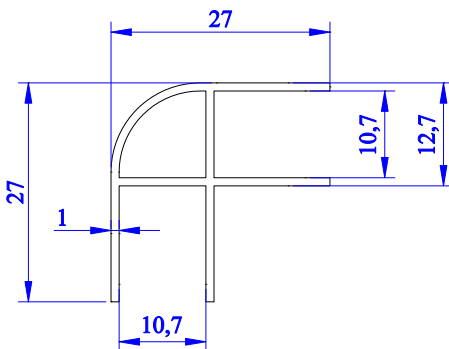

4089 - 0.270 kg/m

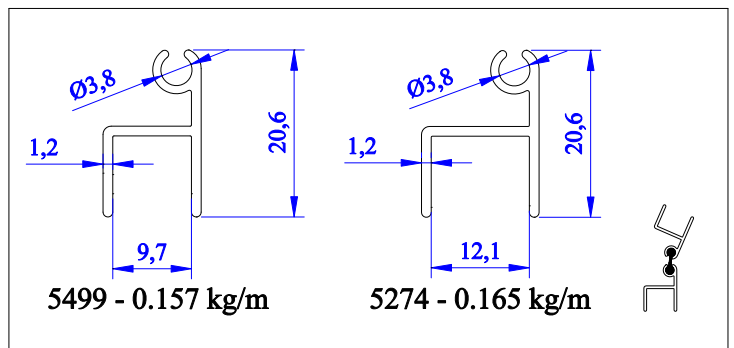

5499 - 0.157 kg/m

5274 - 0.165 kg/m

ALÜMİNYUM KULP PROFİLLERİ

Aluminium Handles Profiles

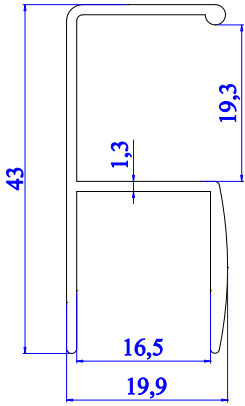

4744 - 0.364 kg/m

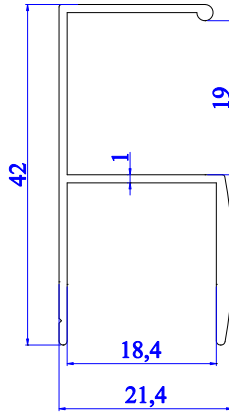

4925 - 0.309 kg/m

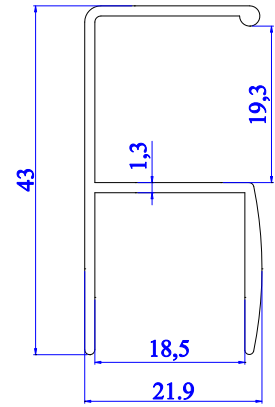

4730 - 0.380 kg/m

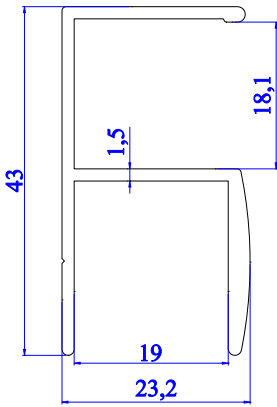

3932 - 0.481 kg/m

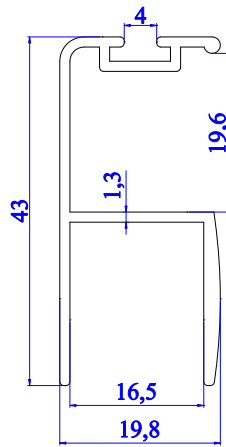

4748 - 0.396 kg/m

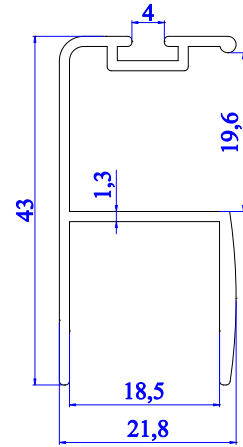

4862 - 0.410 kg/m

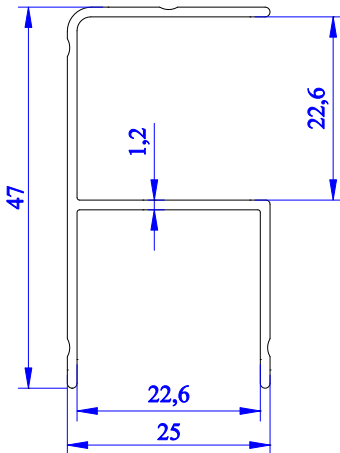

1845 - 0.367 kg/m

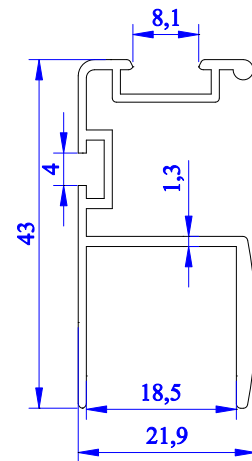

5254 - 0,419 kg/m

ALÜMİNYUM KULP PROFİLLERİ

Aluminium Handles Profiles

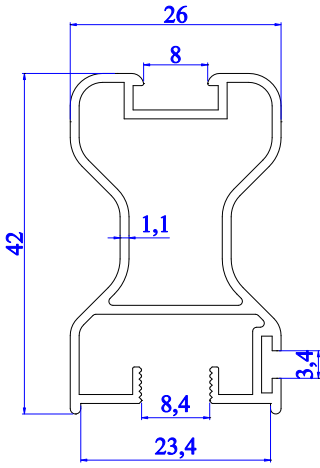

4044- 0.515 kg/m

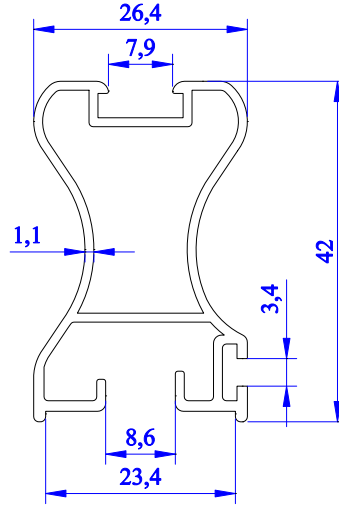

4274 - 0.514 kg/m

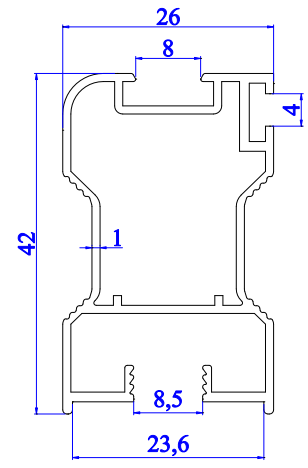

4755- 0.476 kg/m

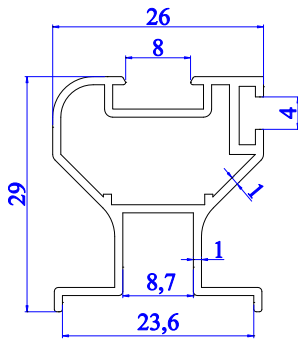

4754- 0.363 kg/m

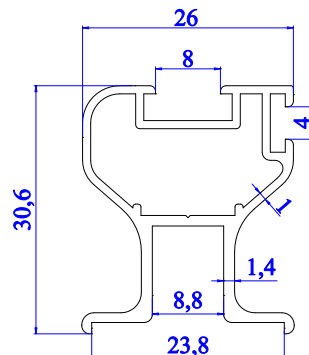

5099- 0.410 kg/m

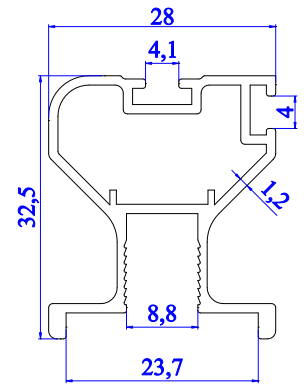

4493 - 0.456 kg/m

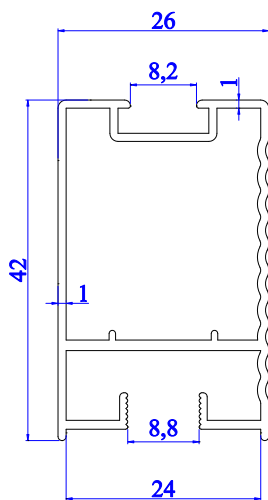

4865 - 0.471 kg/m

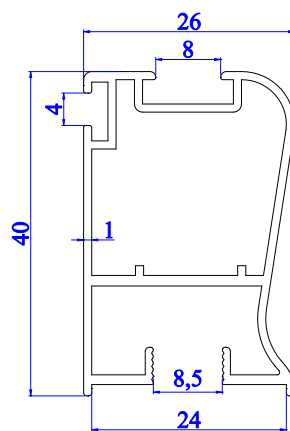

4866 - 0.475 kg/m

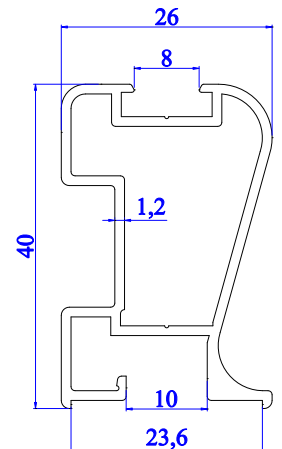

5051 - 0.512 kg/m

ALÜMİNYUM KULP PROFİLLERİ

Aluminium Handles Profiles

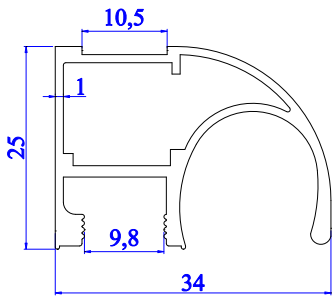

4721 - 0.428 kg/m

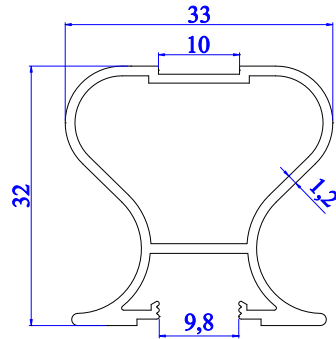

4720 - 0.444 kg/m

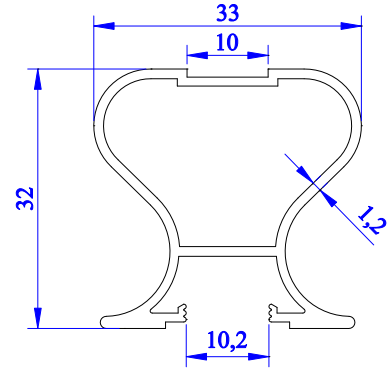

4995 - 0.442 kg/m

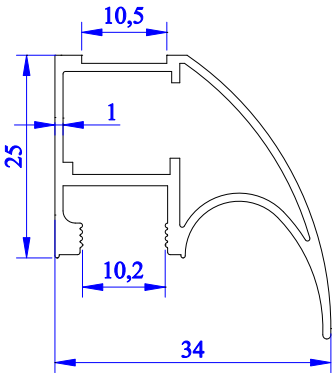

4996 - 0.430 kg/m

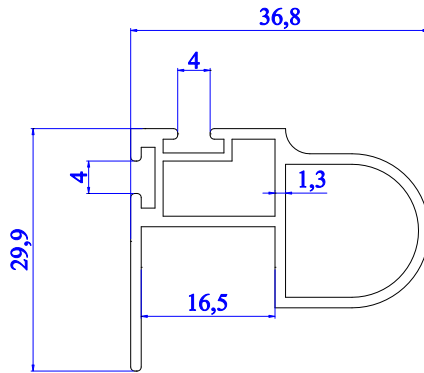

4750 - 0.479 kg/m

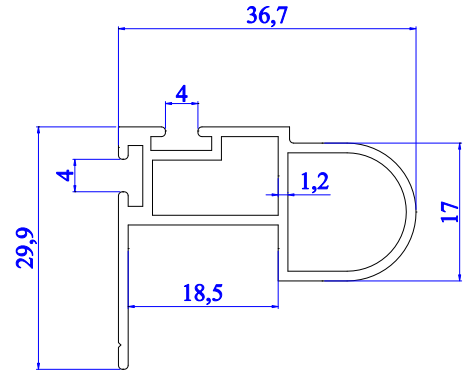

4926 - 0.454 kg/m

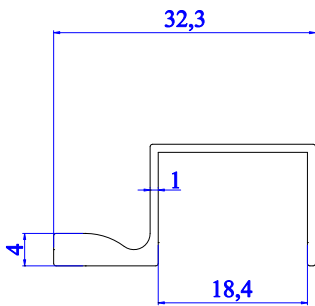

4968 - 0.238 kg/m

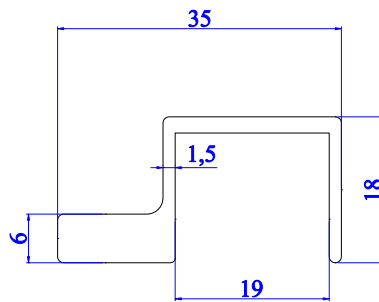

4288 - 0.459 kg/m

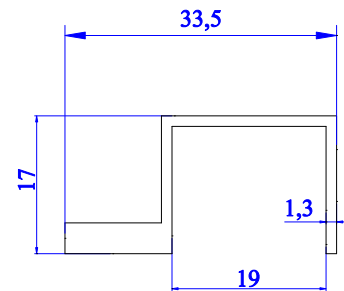

5493 - 0.308 kg/m

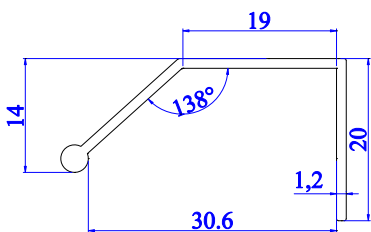

5136 - 0.202 kg/m

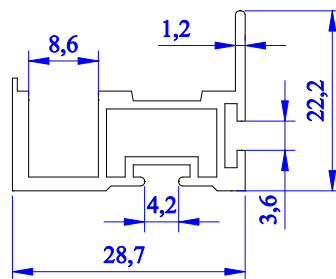

4888 - 0.362 kg/m

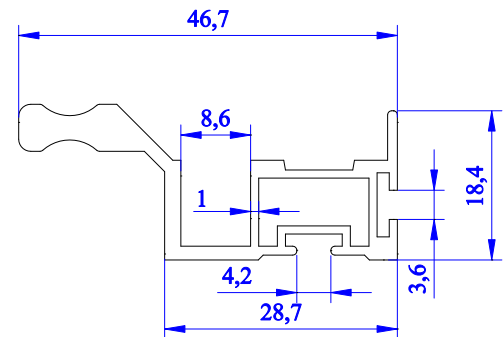

4889 - 0.553 kg/m

ALÜMİNYUM KULP PROFİLLERİ

Aluminium Handles Profiles

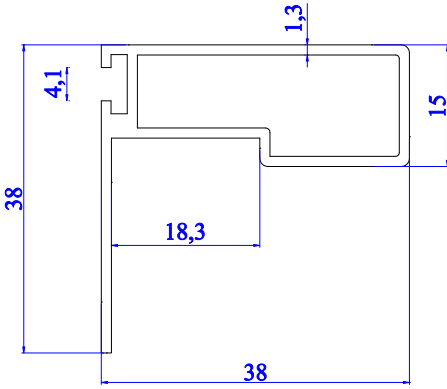

4494 - 0.454 kg/m

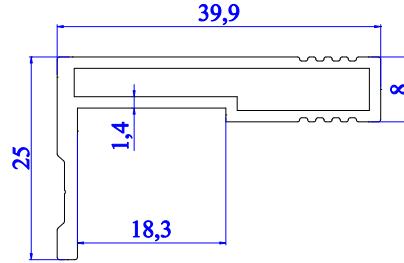

4776 - 0.442 kg/m

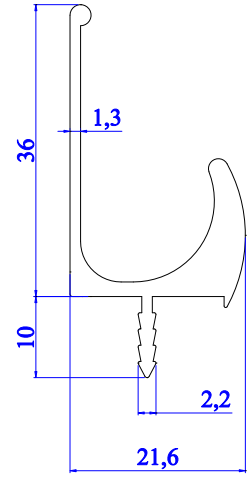

4969 - 0.480 kg/m
yan kulp

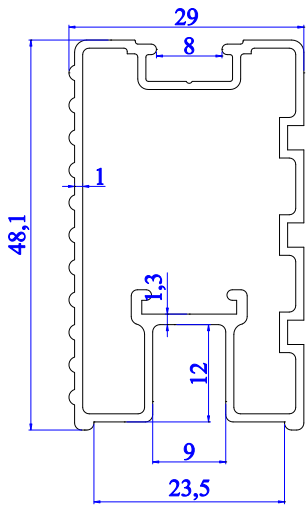

5152 - 0.618 kg/m

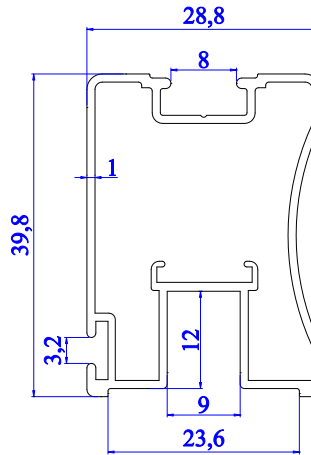

5157 - 0.503 kg/m

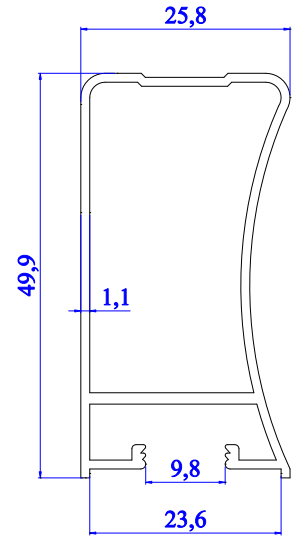

4722- 0.497 kg/m

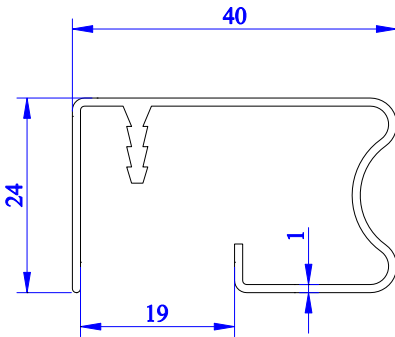

1746 - 0.352 kg/m

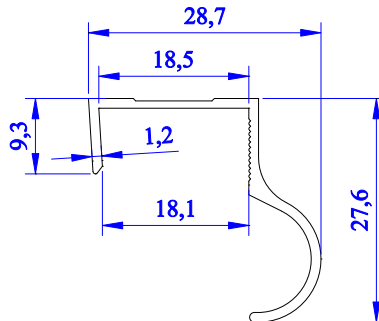

5455 - 0.203 kg/m

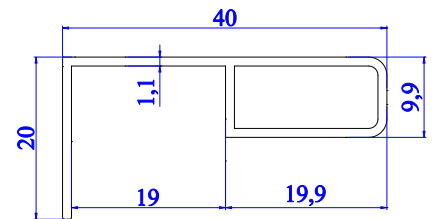

5135 - 0.275 kg/m

ALÜMİNYUM KULP PROFİLLERİ

Aluminium Handles Profiles

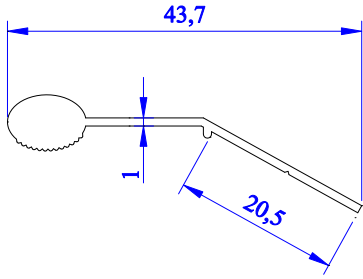

4961 - 0.243 kg/m

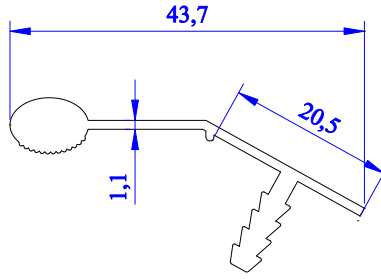

4962 - 0.359 kg/m

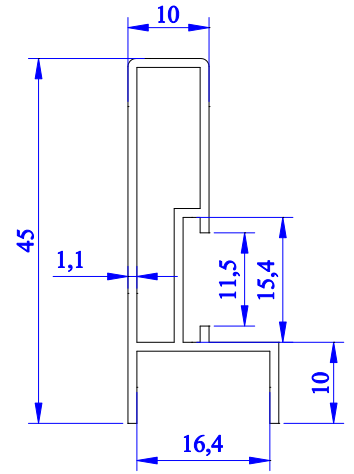

5421 - 0.359 kg/m

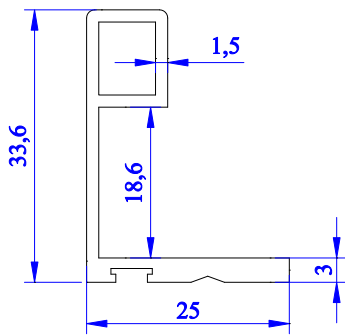

4965 - 0.406 kg/m

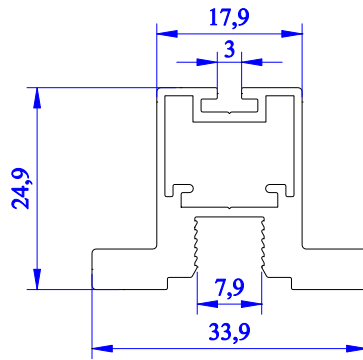

5262 - 0.666 kg/m

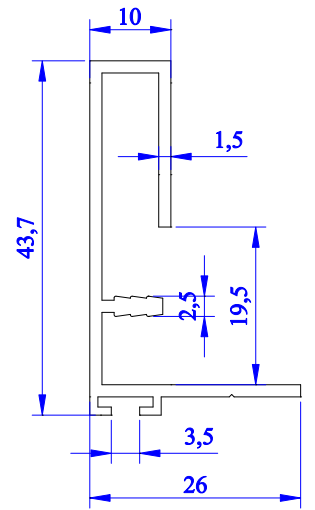

5404 - 0.442 kg/m

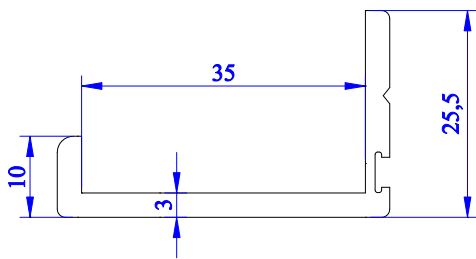

5445 - 0.544 kg/m

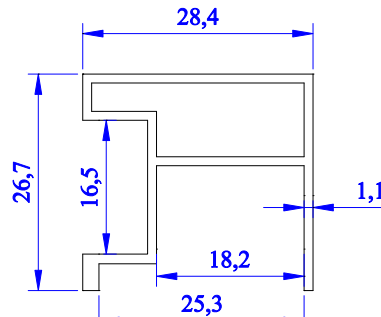

5446 - 0.348 kg/m

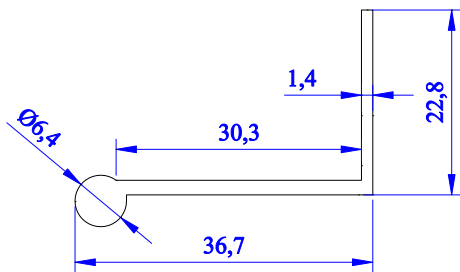

2930 - 0.315 kg/m

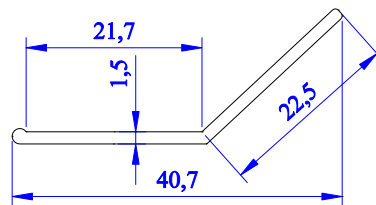

4290 - 0.189 kg/m

ALÜMİNYUM KULP PROFİLLERİ

Aluminium Handles Profiles

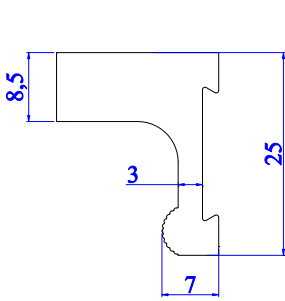

5256 - 0,634 kg/m

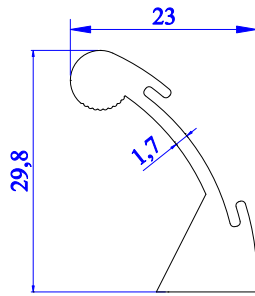

5257 - 0,489 kg/m

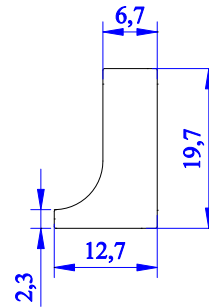

5112 - 0,413 kg/m

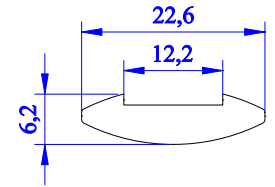

5110 - 0,255 kg/m

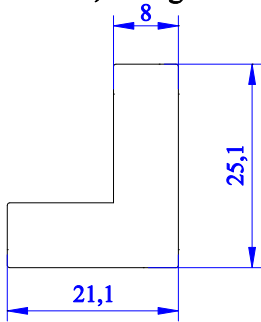

4767 - 0,824 kg/m

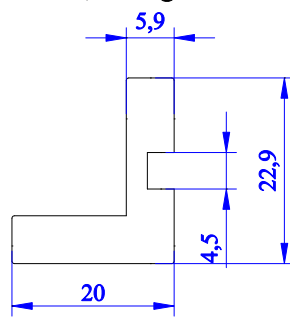

4768 - 0,548 kg/m

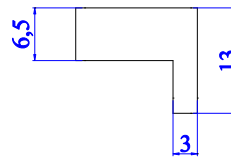

5255 - 0,316 kg/m

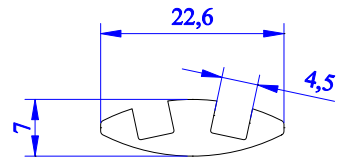

5111 - 0,220 kg/m

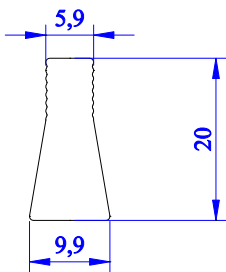

4769 - 0,386 kg/m

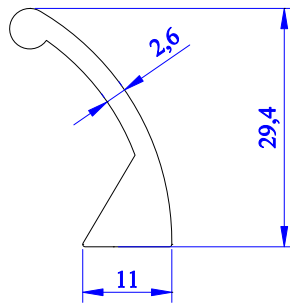

4770 - 0,414 kg/m

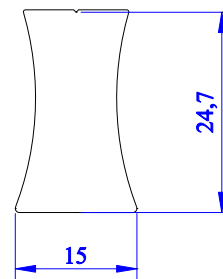

5057 - 0,773 kg/m

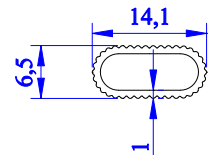

5273 - 0,078 kg/m

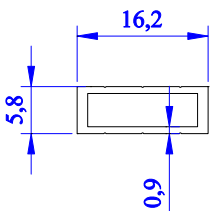

5107 - 0,103 kg/m

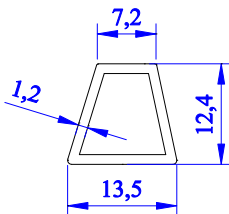

5108 - 0,135 kg/m

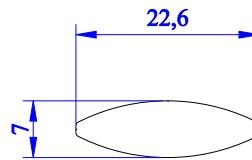

5109 - 0,318 kg/m

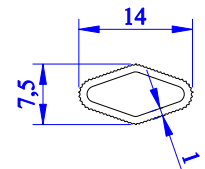

5258 - 0,075 kg/m

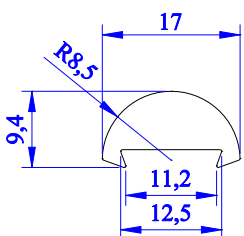

5428 - 0,270 kg/m

ALÜMİNYUM KENAR KAPAMA PROFİLLERİ

Aluminium Last Finished Profiles

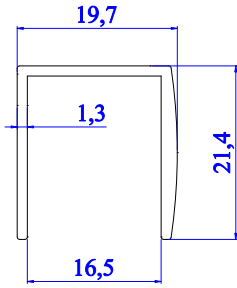

4745 - 0.228 kg/m

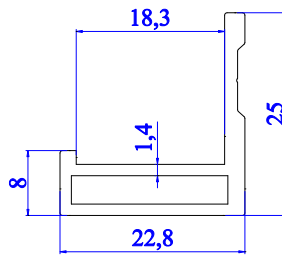

4777 - 0.321 kg/m

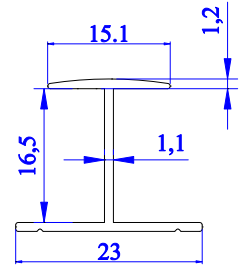

5275 - 0.157 kg/m

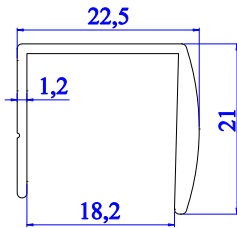

3996 - 0.248 kg/m

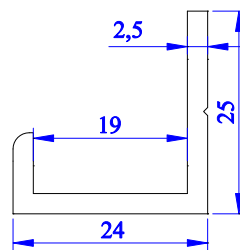

4966 - 0.362 kg/m

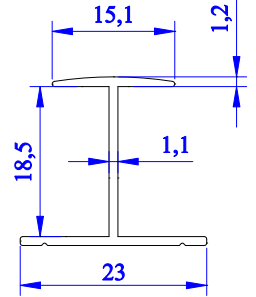

5509 - 0.163 kg/m

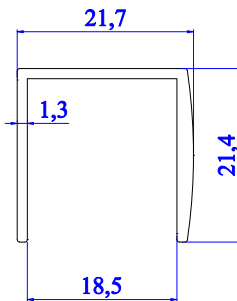

4746 - 0.242 kg/m

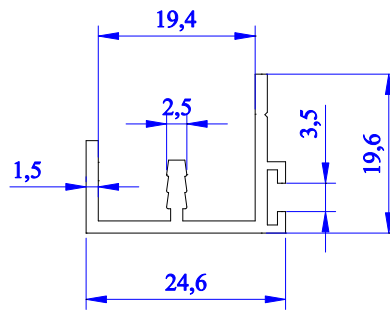

5403 - 0.268 kg/m

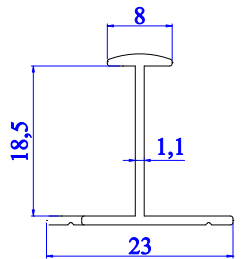

4967 - 0.150 kg/m

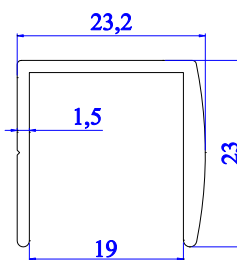

3931 - 0.312 kg/m

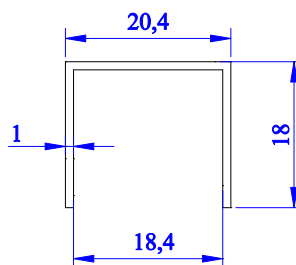

4289 - 0.147 kg/m

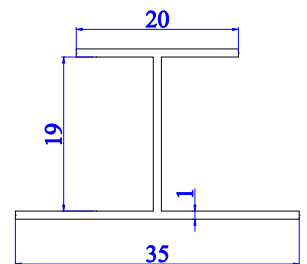

2148 - 0.200 kg/m

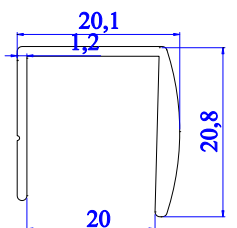

4030 - 0.240 kg/m

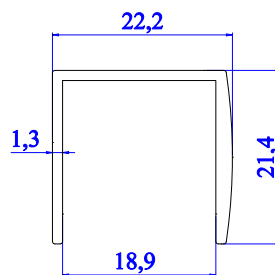

4910 - 0.238 kg/m

ALÜMİNYUM KENAR KAPAMA PROFİLLERİ

Aluminium Last Finished Profiles

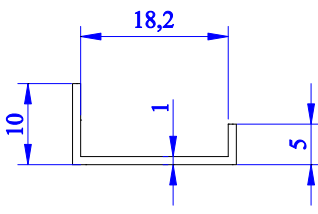

4997 - 0.090 kg/m

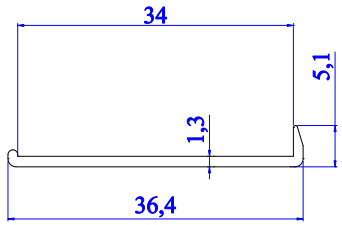

4847 - 0.139 kg/m

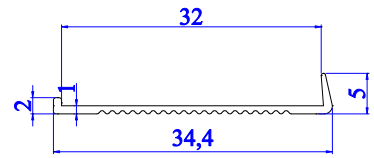

4927 - 0.090 kg/m

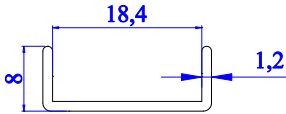

4658 - 0.110 kg/m

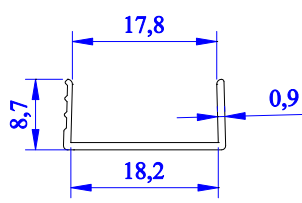

4935 - 0.082 kg/m

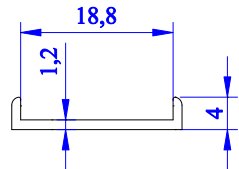

5557 - 0.084 kg/m

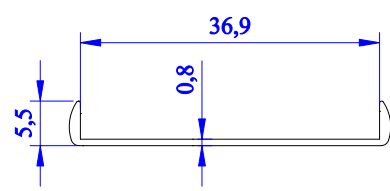

5558 - 0.113 kg/m

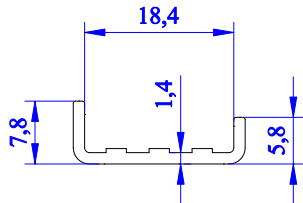

4773 - 0.127 kg/m

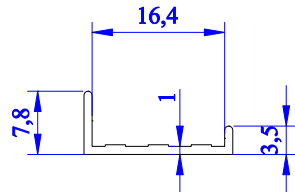

4897 - 0.079 kg/m

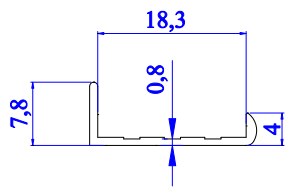

4764 - 0.078 kg/m

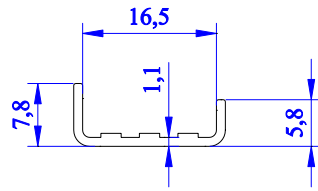

4984 - 0.096 kg/m

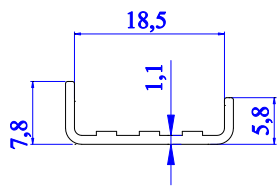

4661 - 0.102 kg/m

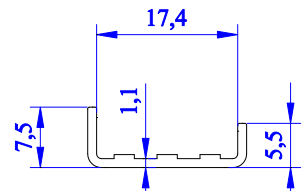

5380 - 0.097 kg/m

ALÜMİNYUM KENAR KAPAMA PROFİLLERİ

Aluminium Last Finished Profiles

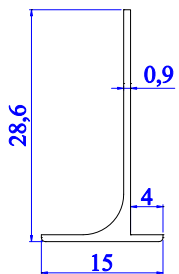

4923 - 0.112 kg/m

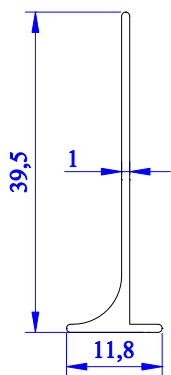

5495 - 0.156 kg/m

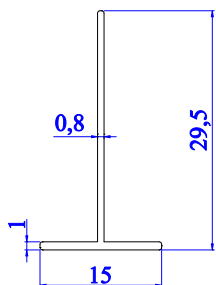

4922 - 0.102 kg/m

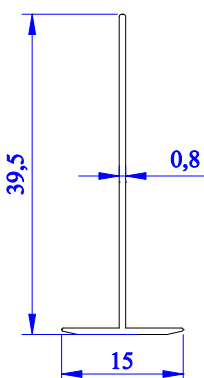

5494 - 0.113 kg/m

5173 - 0.167 kg/m

4763 - 0.263 kg/m

4762 - 0.312 kg/m

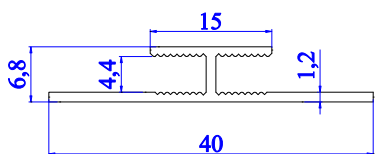

4621 - 0.184 kg/m

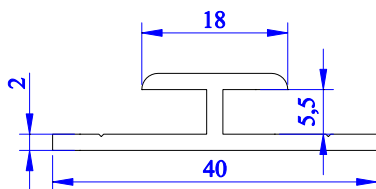

3679 - 0.339 kg/m

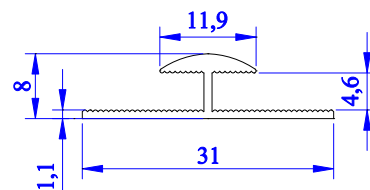

5435 - 0.148 kg/m

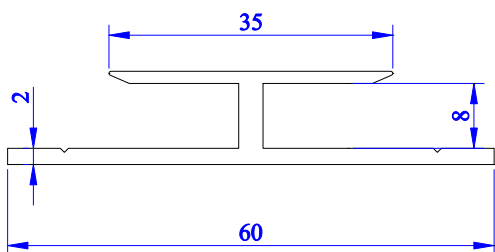

1795 - 0.521 kg/m

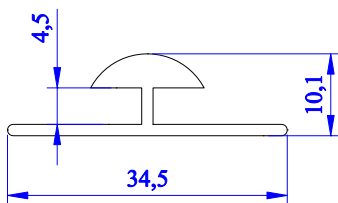

3621 - 0.261 kg/m

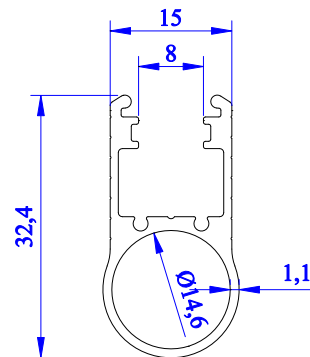

5319 - 0.343 kg/m

ALÜMİNYUM KENAR KAPAMA PROFİLLERİ

Aluminium Last Finished Profiles

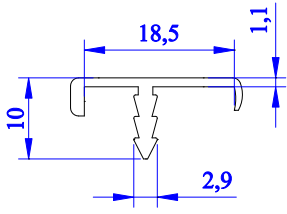

5341 - 0.134 kg/m

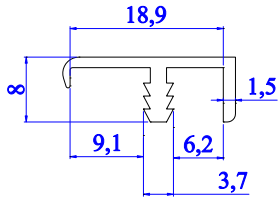

3934 - 0.152 kg/m

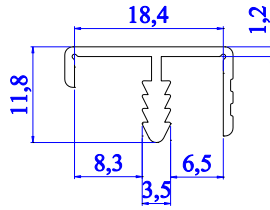

4042 - 0.172 kg/m

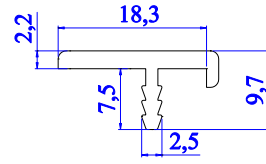

4970 - 0.163 kg/m

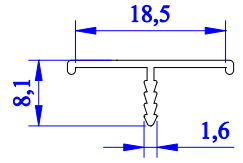

4983 - 0.087 kg/m

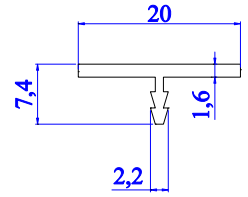

3935 - 0.109 kg/m

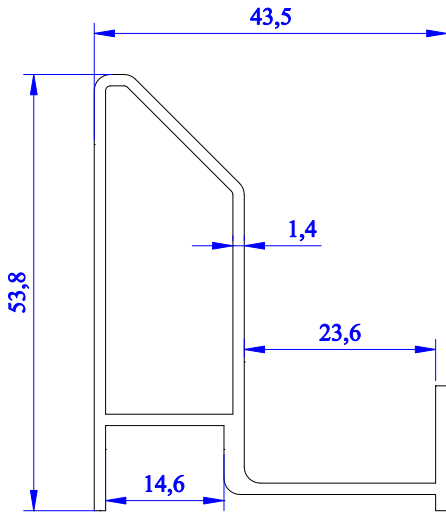

5346 - 0.658 kg/m

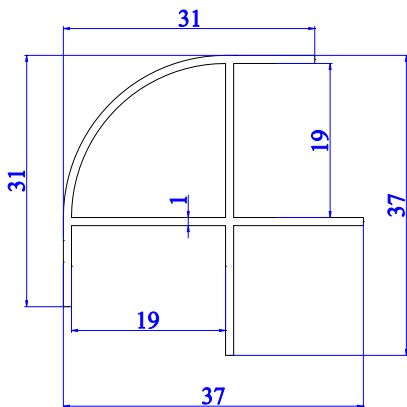

2150 - 0.335 kg/m

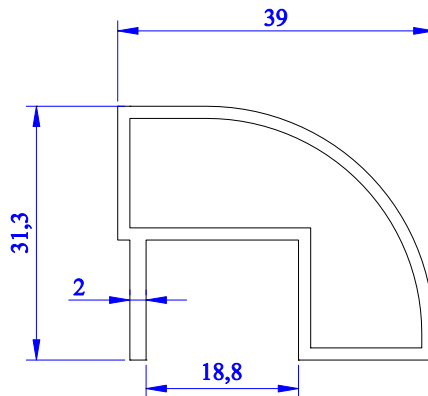

5422 - 0.578 kg/m

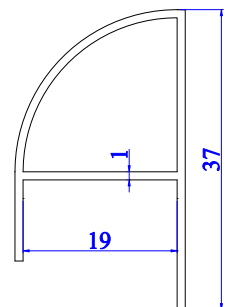

2151 - 0.262 kg/m

ALÜMİNYUM ÇERÇEVE KAPAK PROFİLLERİ

Aluminium Frame Covers Profiles

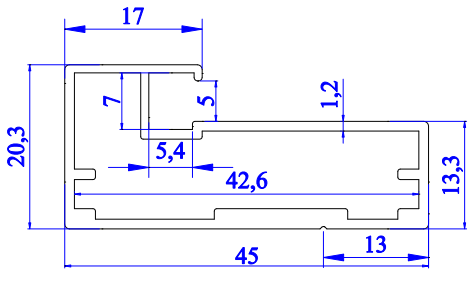

4710 - 0.518 kg/m

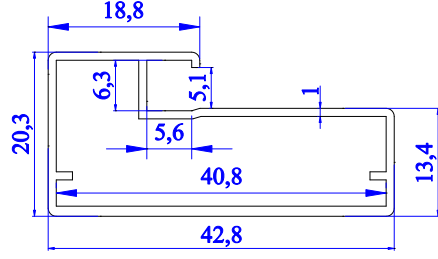

4864 - 0.387 kg/m

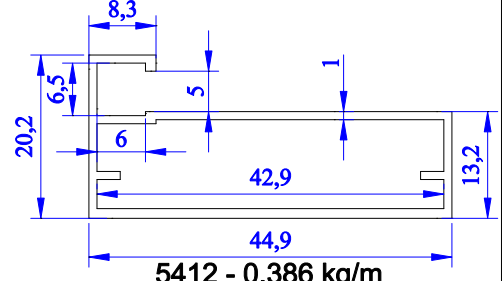

5412 - 0.386 kg/m

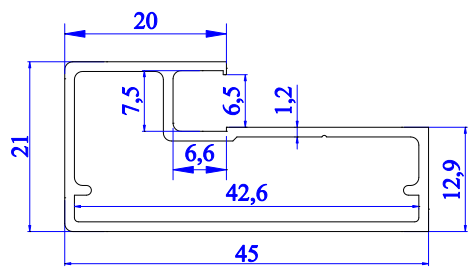

4933 - 0.449 kg/m

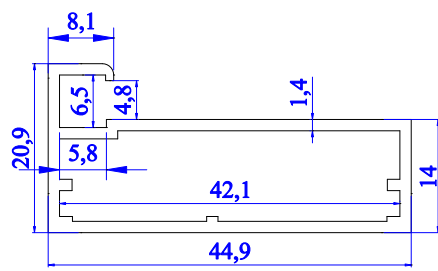

4771 - 0.500 kg/m

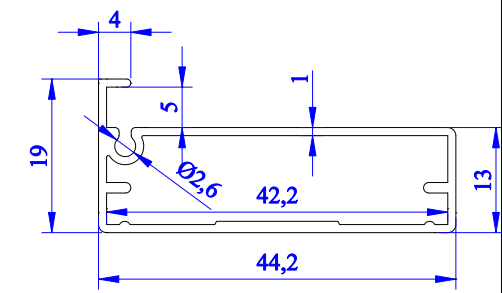

5381 - 0.378 kg/m

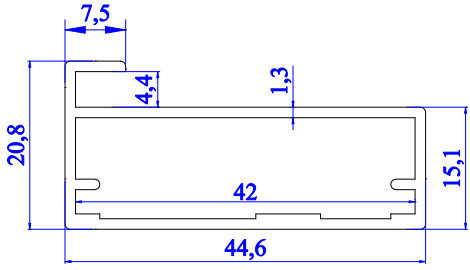

4209 - 0.486 kg/m

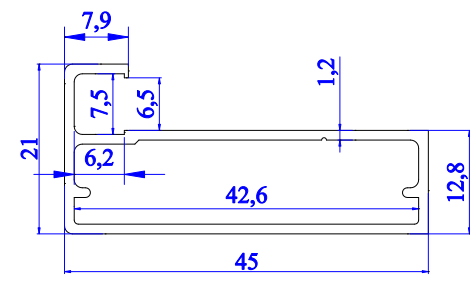

5052 - 0.425 kg/m

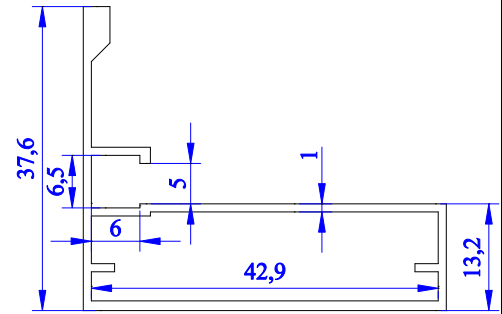

5413 - 0.468 kg/m

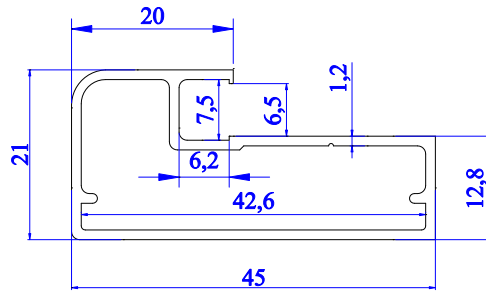

5050 - 0.447 kg/m

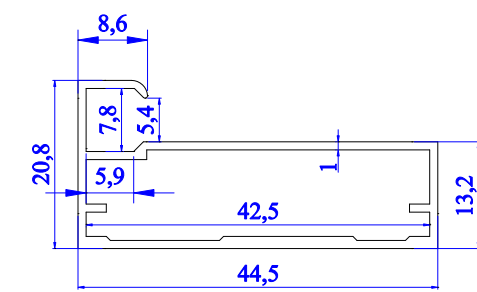

5033 - 0.389 kg/m

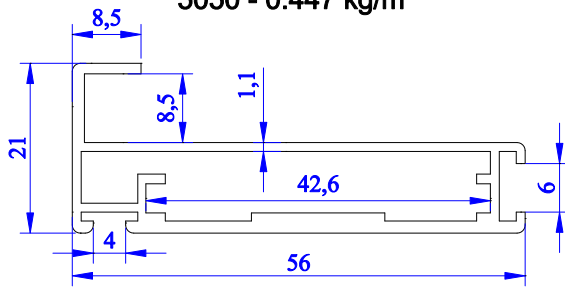

5426 - 0.602 kg/m

ALÜMİNYUM ÇERÇEVE KAPAK PROFİLLERİ

Aluminium Frame Covers Profiles

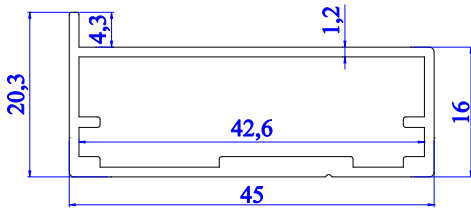

4709 - 0.486 kg/m

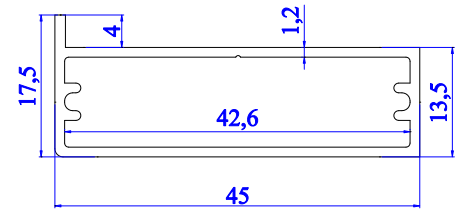

4934 - 0.404 kg/m

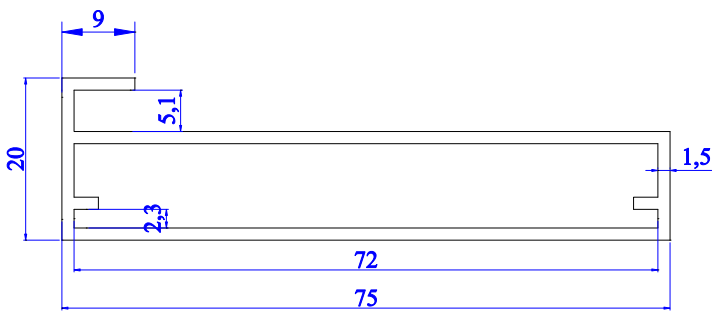

4964 - 0.773 kg/m

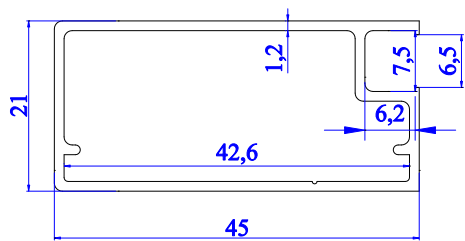

5053 - 0.449 kg/m

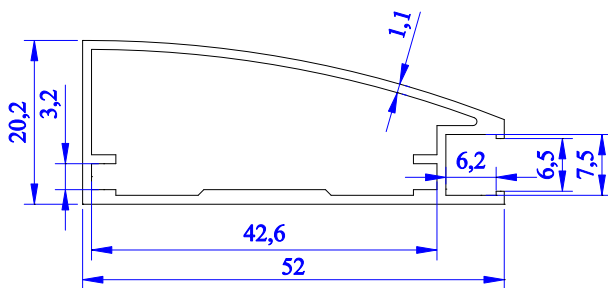

5373 - 0.476 kg/m

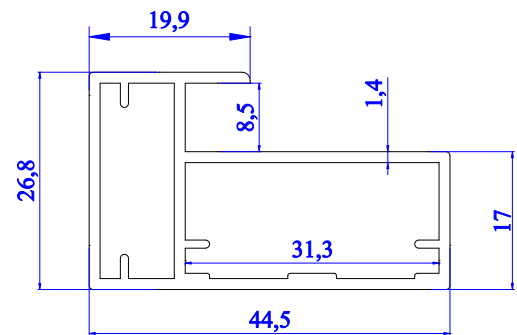

4976 - 0.634 kg/m

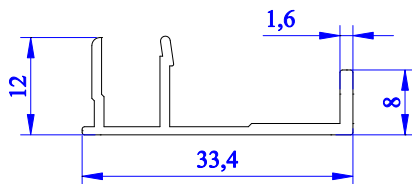

5030 - 0.205 kg/m

ALÜMİNYUM ÇERÇEVE KAPAK PROFİLLERİ

Aluminium Frame Covers Profiles

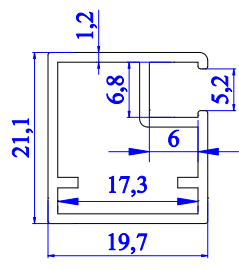

4711 - 0.294 kg/m

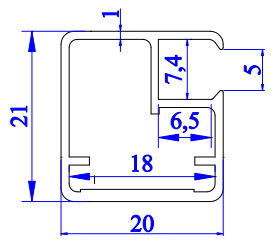

4210 - 0.270 kg/m

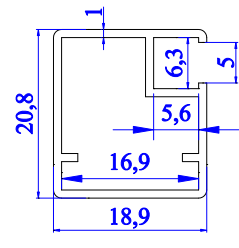

4874 - 0.246 kg/m

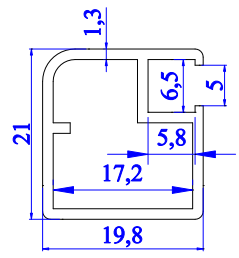
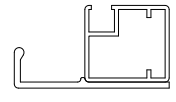

4772 - 0.297 kg/m

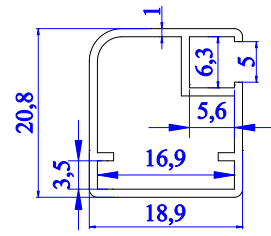

4863 - 0.244 kg/m

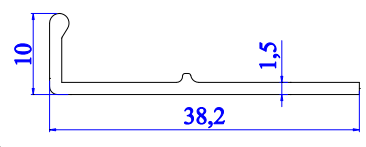

4898 - 0.197 kg/m

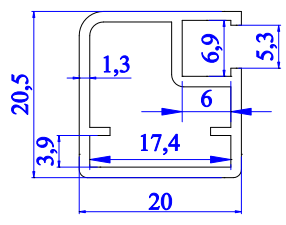

4908 - 0.300 kg/m

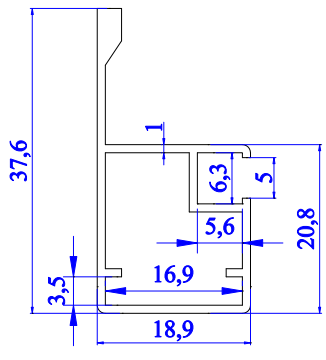

4867 - 0.309 kg/m

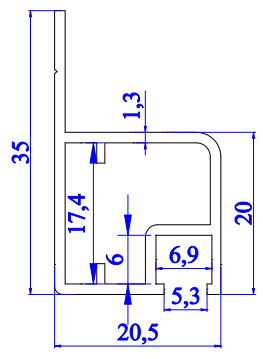

5032 - 0.354 kg/m

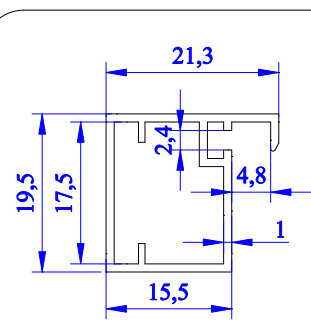

5401 - 0.227 kg/m

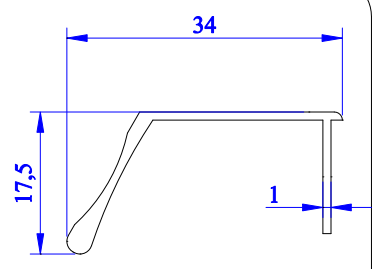

5402 - 0.190 kg/m

ALÜMİNYUM RAY PROFİLLERİ

Aluminium Rail Profiles

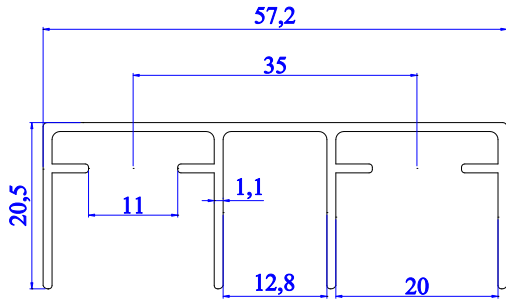

4731 - 0.456 kg/m

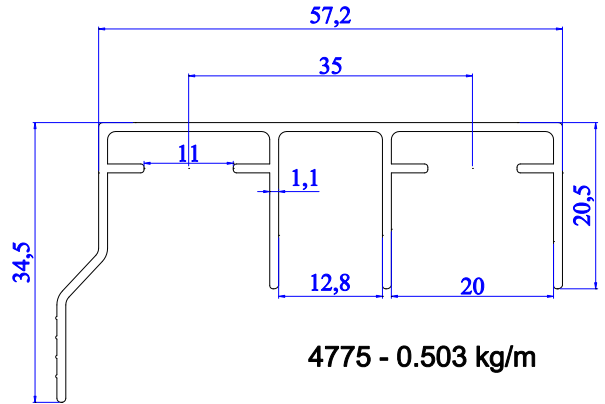

4775 - 0.503 kg/m

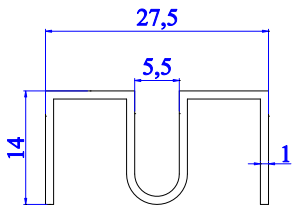

4814 - 0.207 kg/m

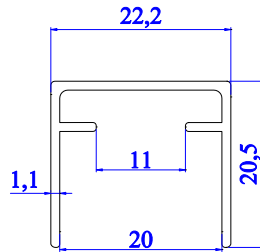

4757 - 0.202 kg/m

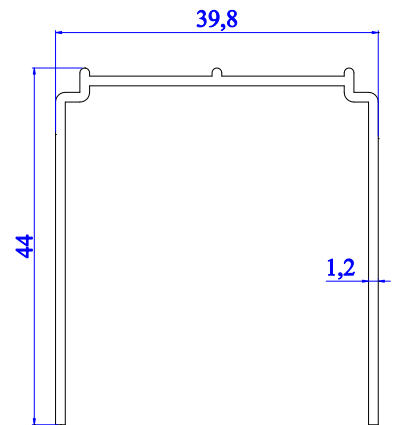

4713 - 0.405 kg/m

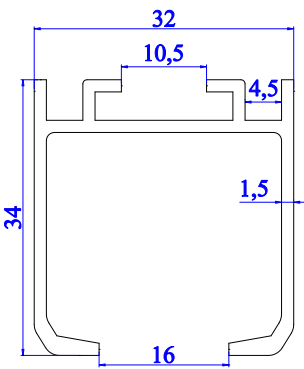

3887 - 0.522 kg/m

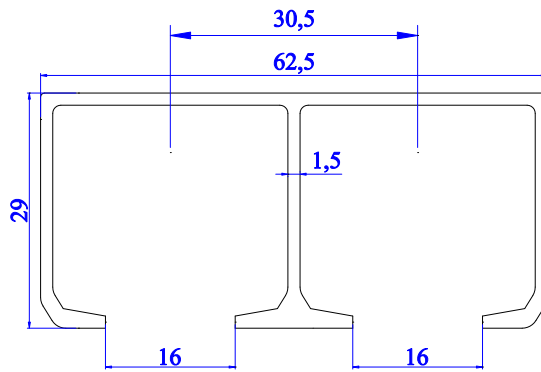

3886 - 0.730 kg/m

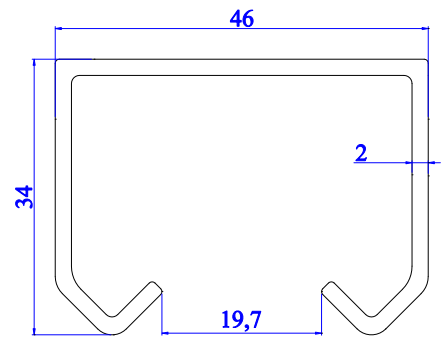

3888 - 0.700 kg/m

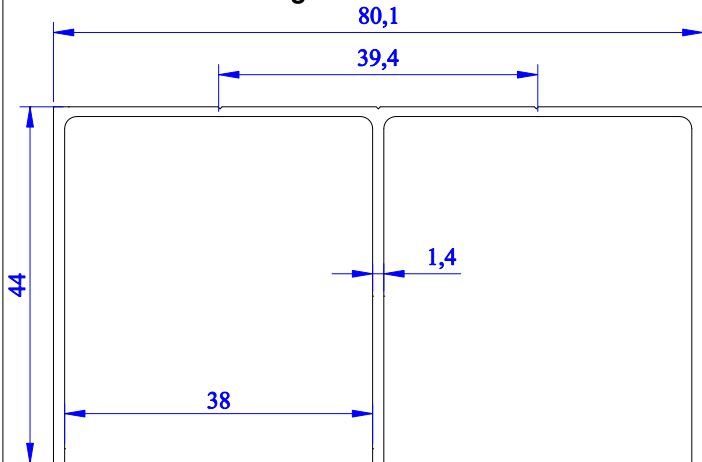

5410 - 0.743 kg/m

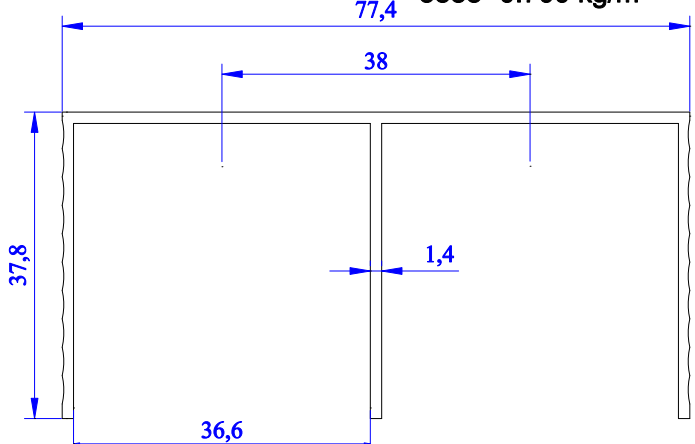

5243 - 0.680 kg/m

ALÜMİNYUM RAY PROFİLLERİ

Aluminium Rail Profiles

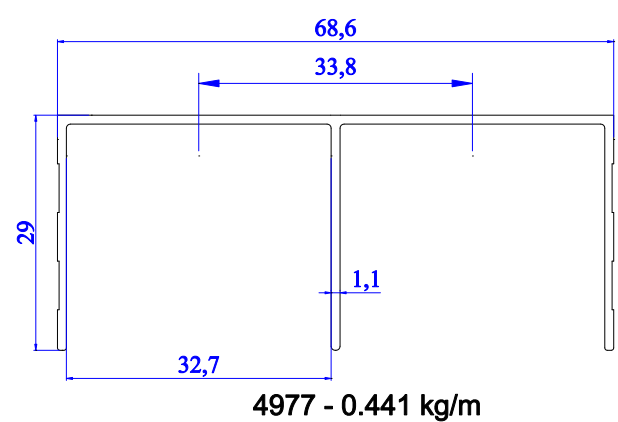
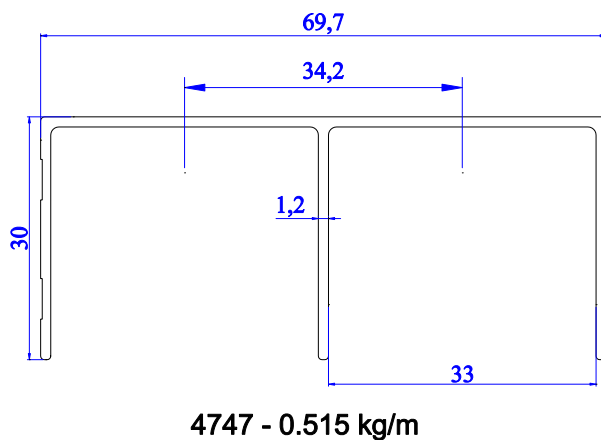
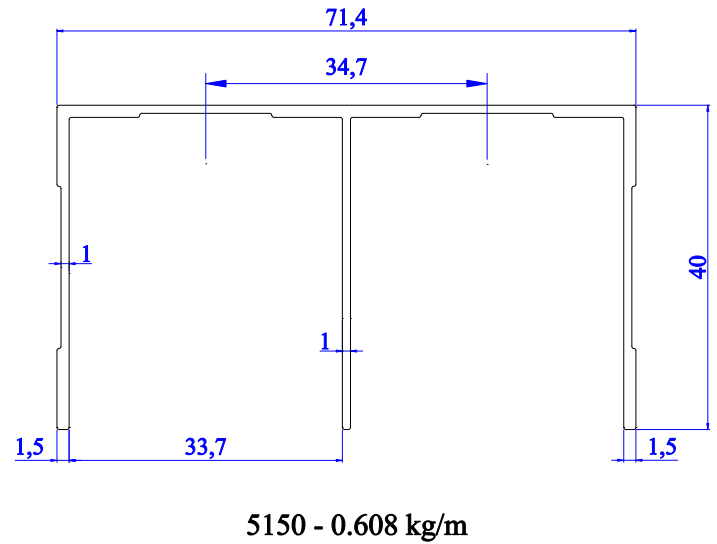
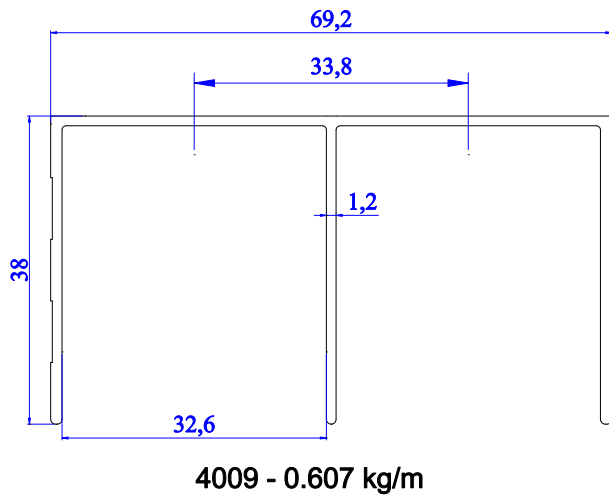
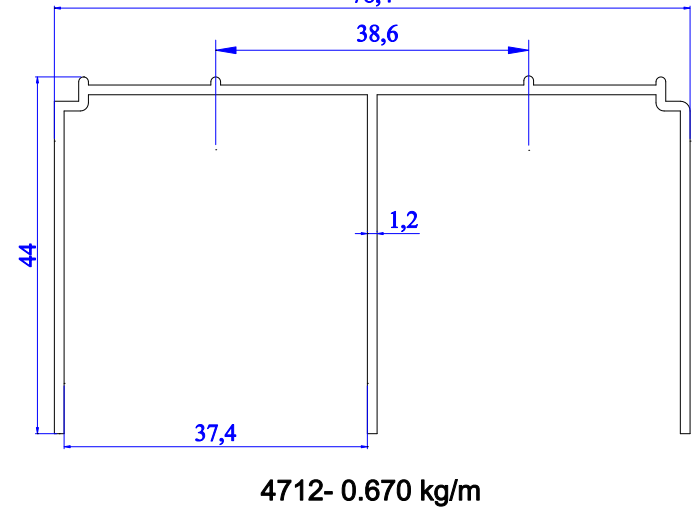
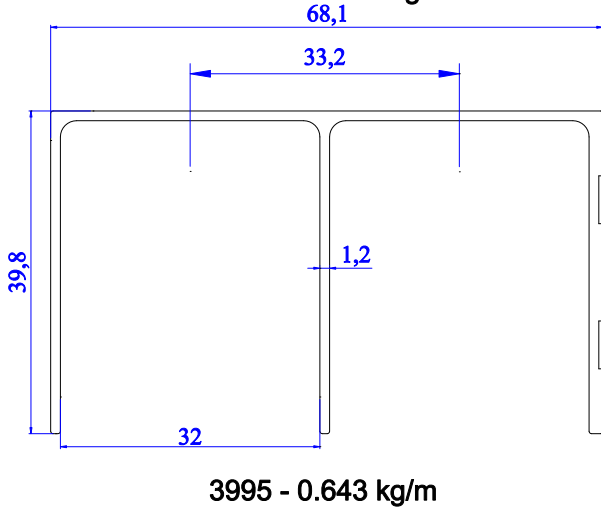
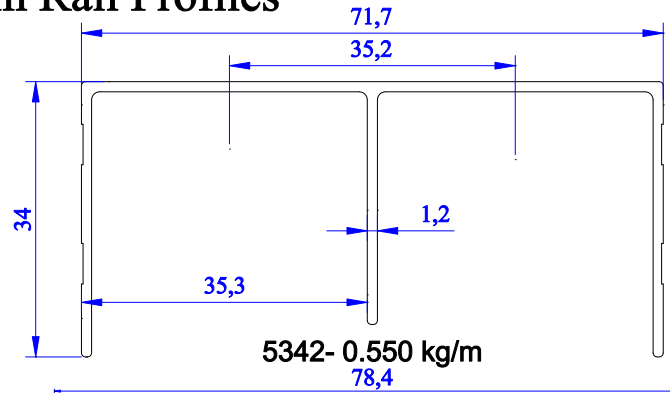
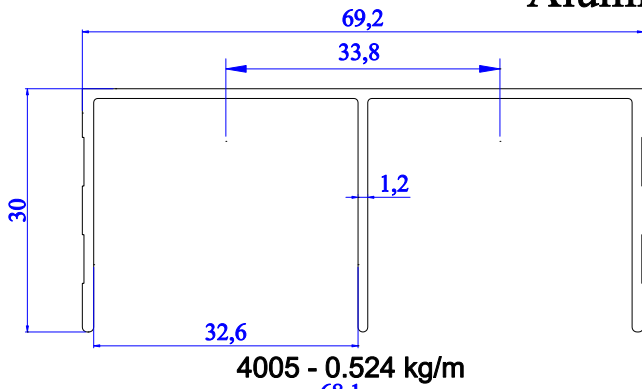

ALÜMİNYUM RAY PROFİLLERİ

Aluminium Rail Profiles

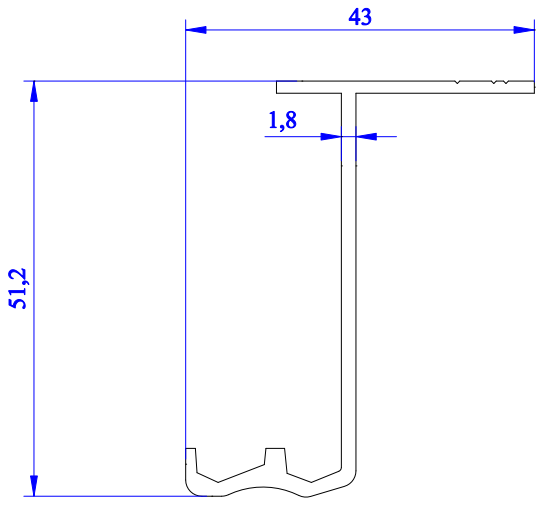

5310 - 0.502 kg/m

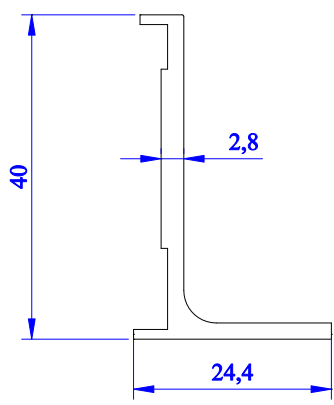

4972 - 0.396 kg/m

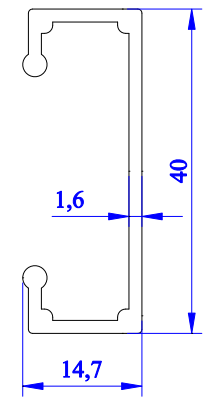

4973 - 0.269 kg/m

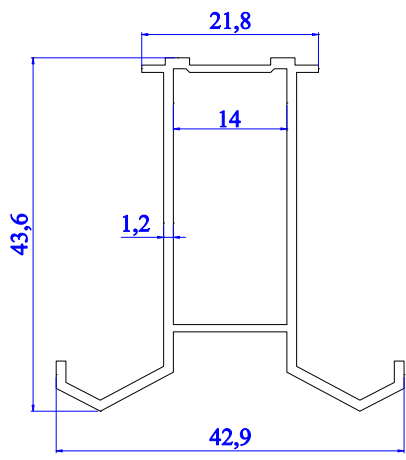

4529 - 0.451 kg/m

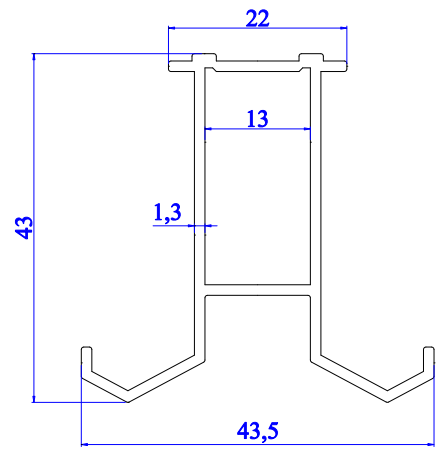

4841 - 0.517 kg/m

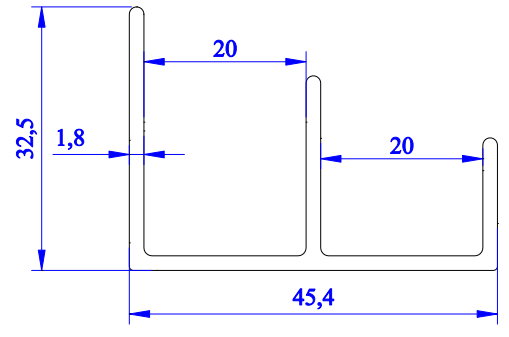

5311 - 0.548 kg/m

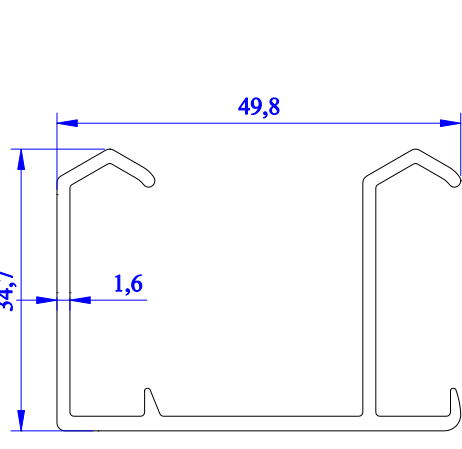

5309 - 0.623 kg/m

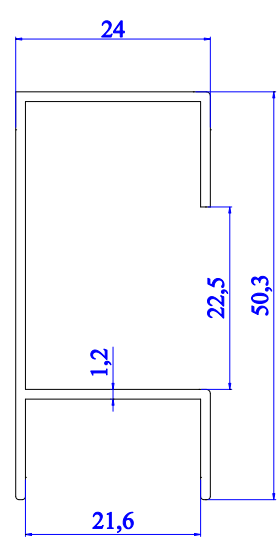

4528 - 0.392 kg/m

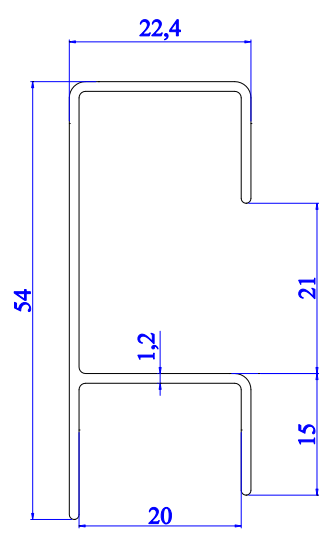

4840 - 0.396 kg/m

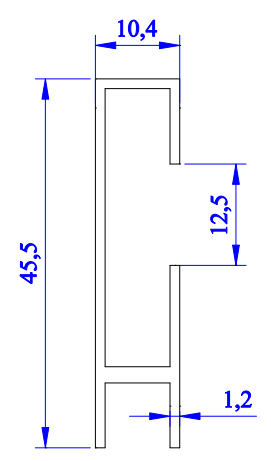

5184 - 0.324 kg/m

ALÜMİNYUM RAY PROFİLLERİ

Aluminium Rail Profiles

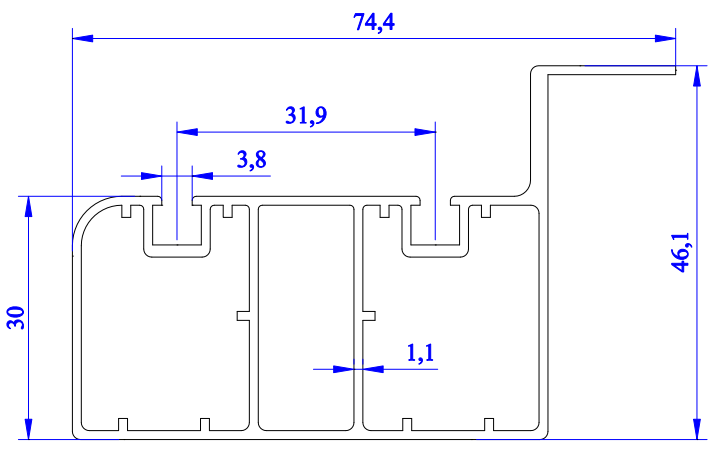

5171 - 0.962 kg/m

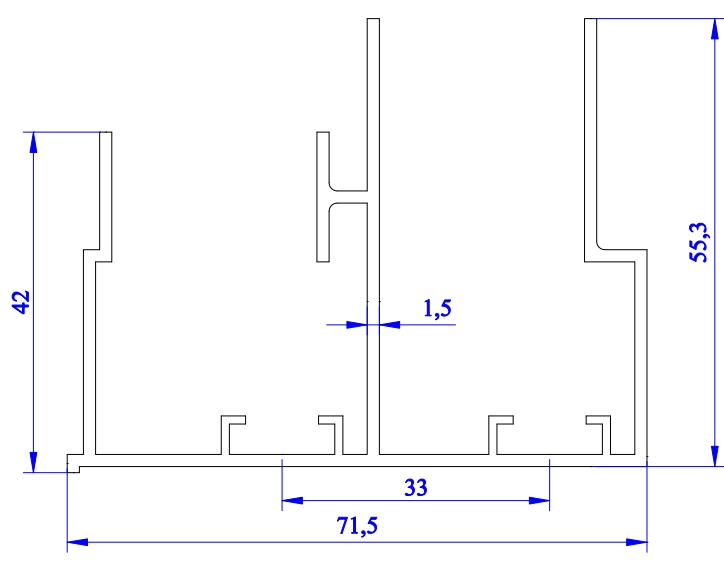

5172 - 1.081 kg/m

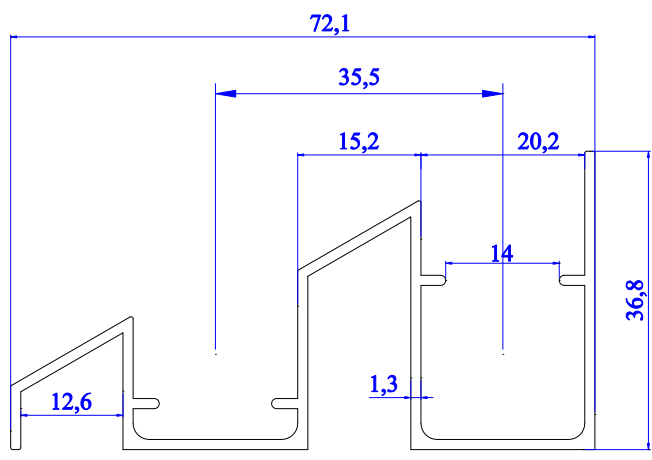

5134 - 0.670 kg/m

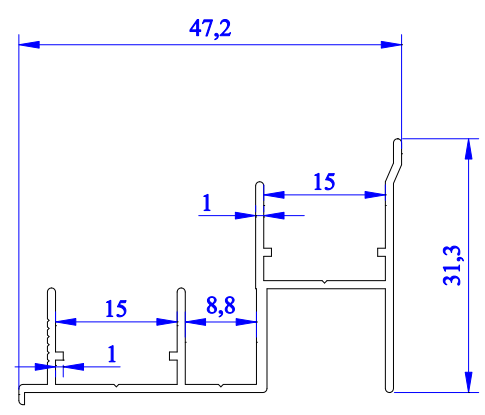

5488 - 0.359 kg/m

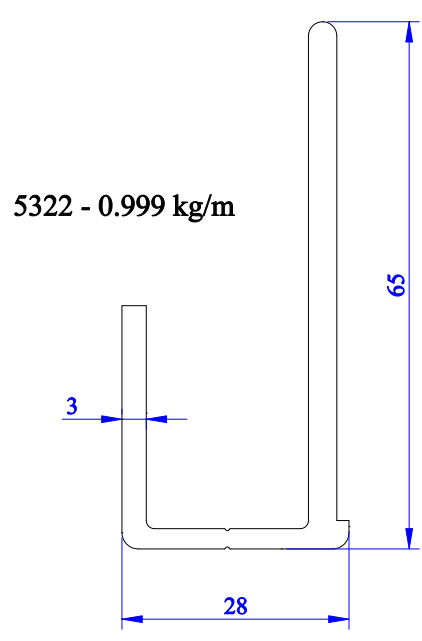

5322 - 0.999 kg/m

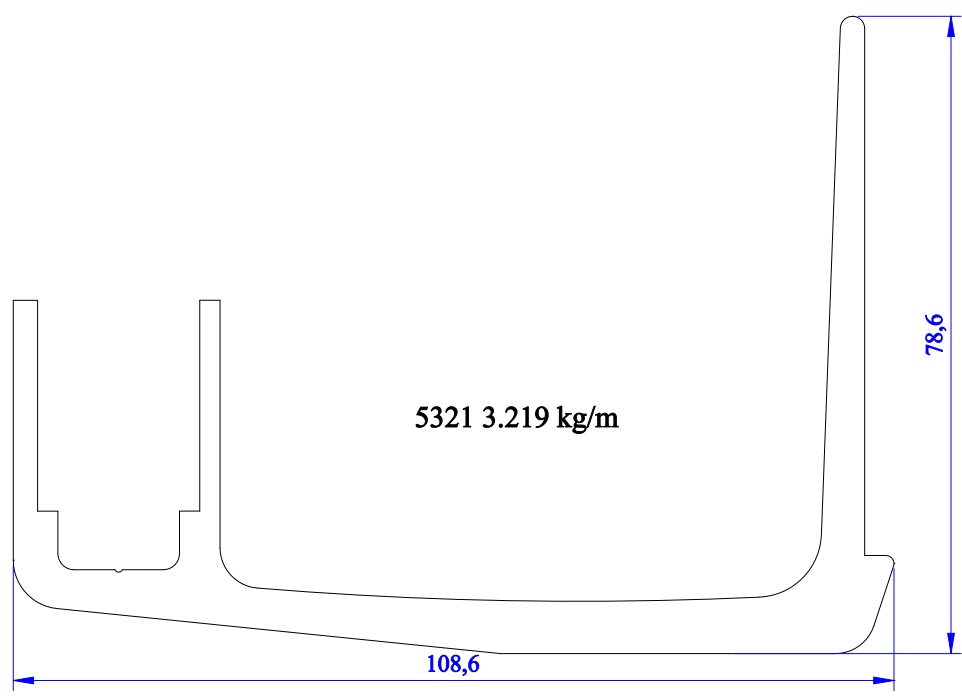

5321 3.219 kg/m

ALÜMİNYUM RAY PROFİLLERİ

Aluminium Rail Profiles

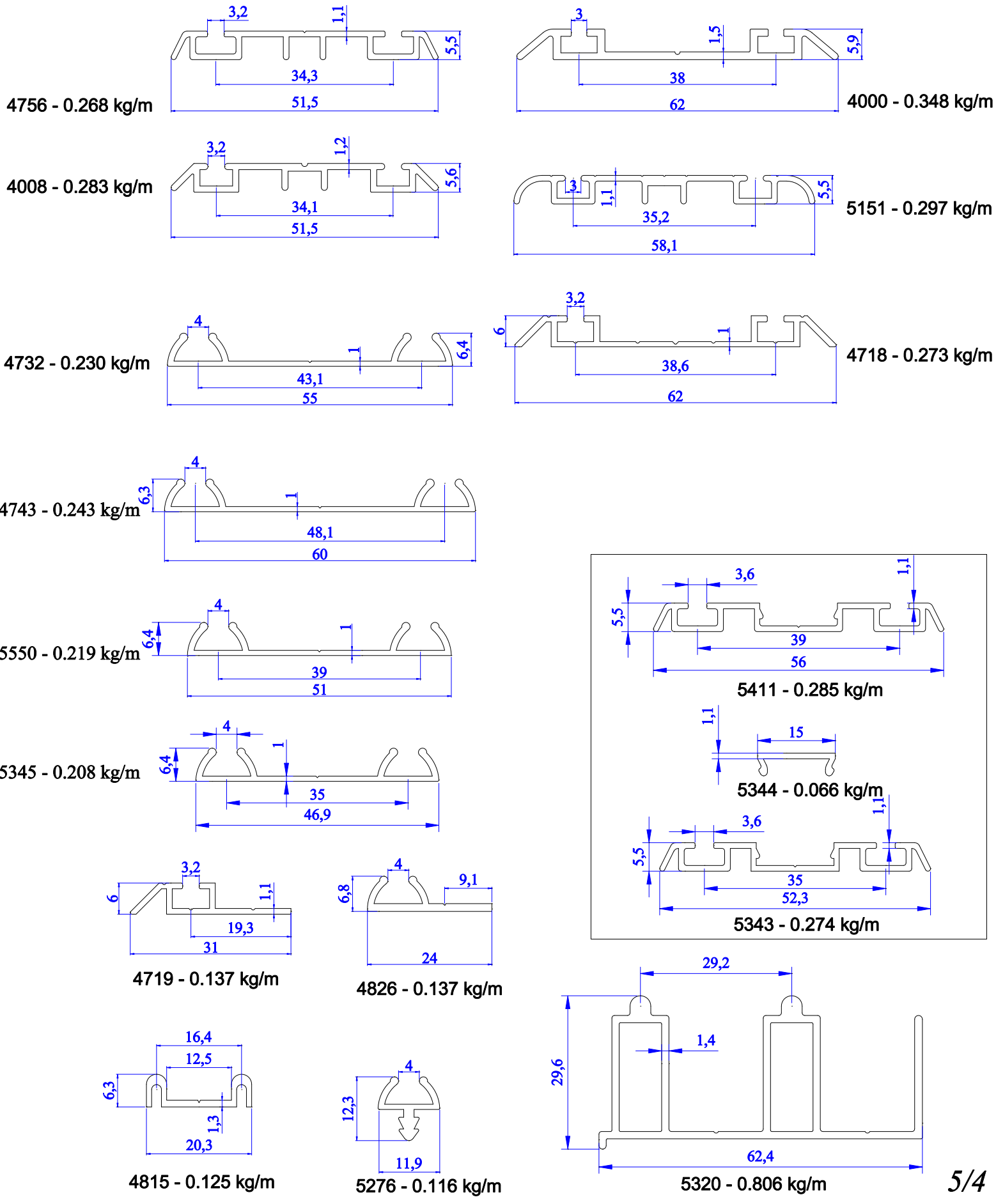

ALÜMİNYUM RAY PROFİLLERİ

Aluminium Rail Profiles

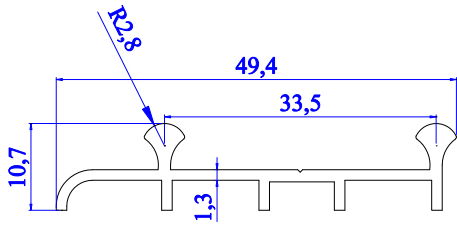

4007 - 0.319 kg/m

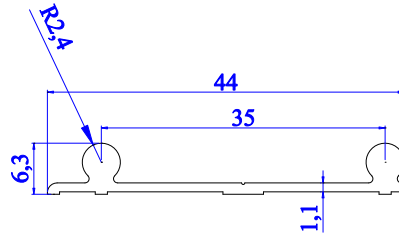

4971 0.237 kg/m

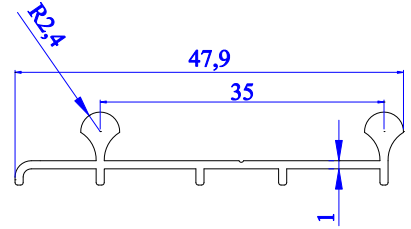

4749 - 0.240 kg/m

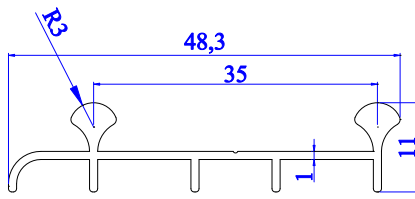

4733 - 0.276 kg/m

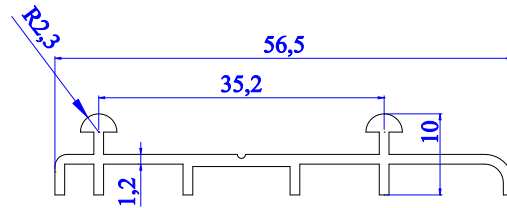

3999 - 0.322 kg/m

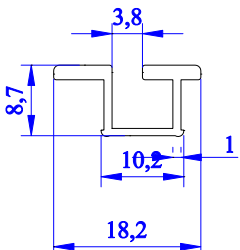

4931 - 0.126 kg/m

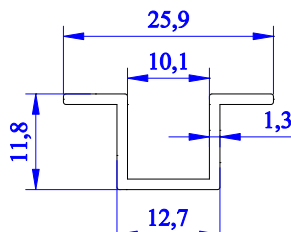

5288 - 0.164 kg/m

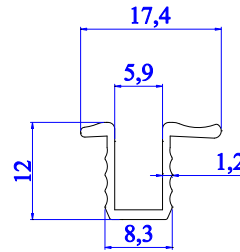

4735 - 0.118 kg/m

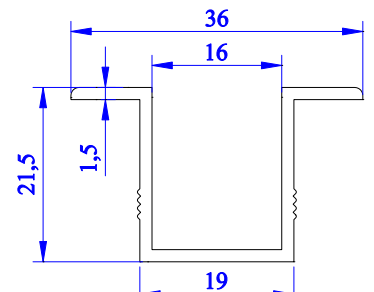

3751 - 0.311 kg/m

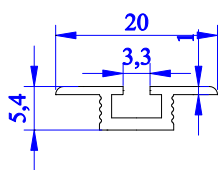

5186 - 0.102 kg/m

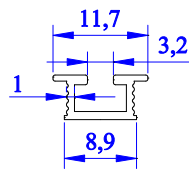

5272 - 0.062 kg/m

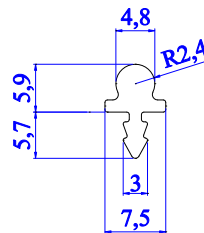

4737 - 0.110 kg/m

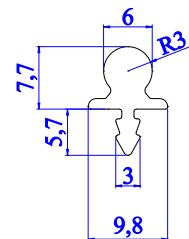

4736 - 0.150 kg/m

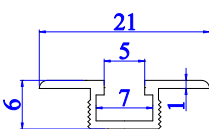

2110 - 0.086 kg/m

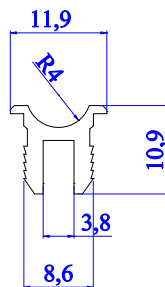

4734 - 0.137 kg/m

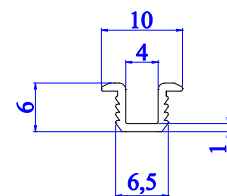

4765 - 0.055 kg/m

ALÜMİNYUM RAY PROFİLLERİ

Aluminium Rail Profiles

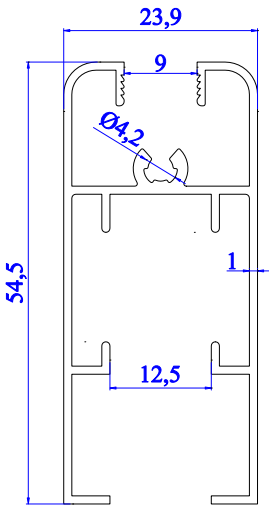

4297 - 0.534 kg/m

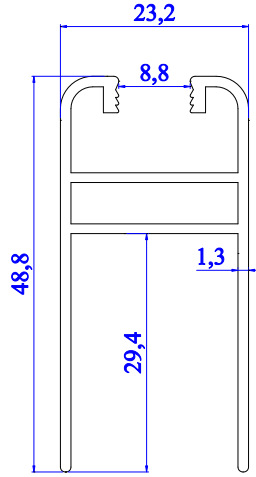

4045 - 0.536 kg/m

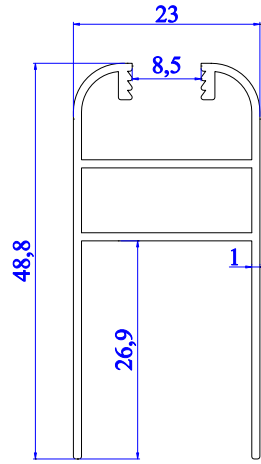

4751 - 0.427 kg/m

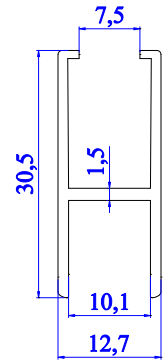

4813 - 0.255 kg/m

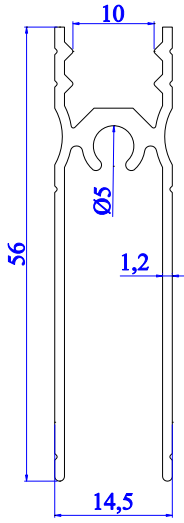

4717 - 0.486 kg/m

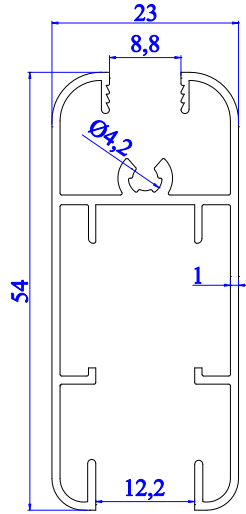

5156 - 0.535 kg/m

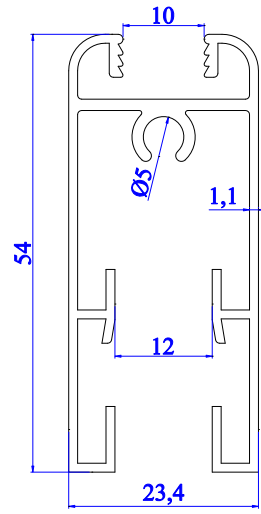

4708 - 0.658 kg/m

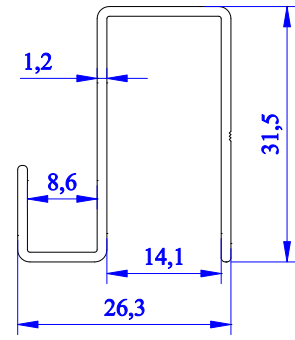

4886 - 0.311 kg/m

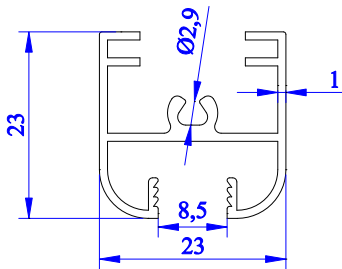

5414 - 0.311 kg/m

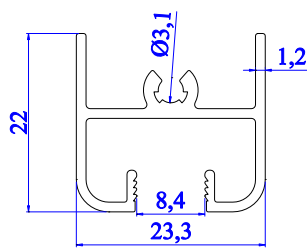

5154 - 0.248 kg/m

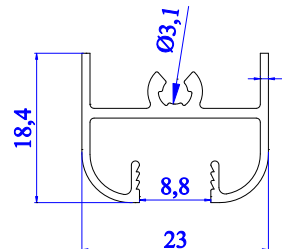

3997 - 0.309 kg/m

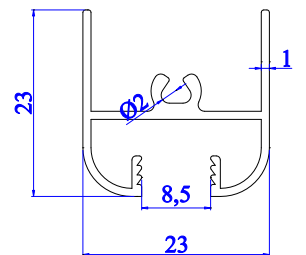

4753 - 0.268 kg/m

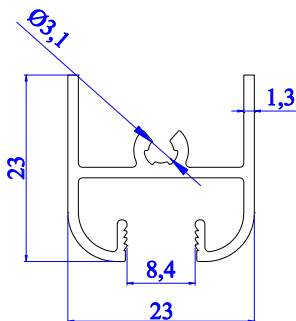

4707 - 0.312 kg/m

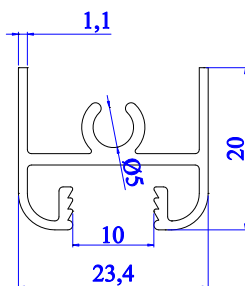

4006 - 0.320 kg/m

ALÜMİNYUM RAY PROFİLLERİ

Aluminium Rail Profiles

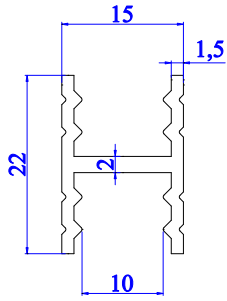

4714 - 0.262 kg/m

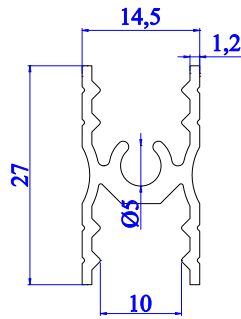

4715 - 0.313 kg/m

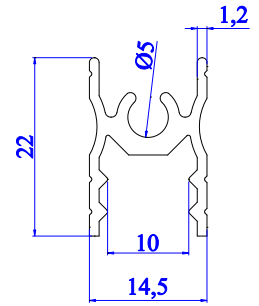

4716 - 0.265 kg/m

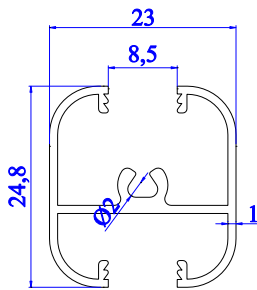

4752 - 0.301 kg/m

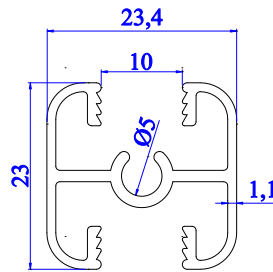

4706 - 0.360 kg/m

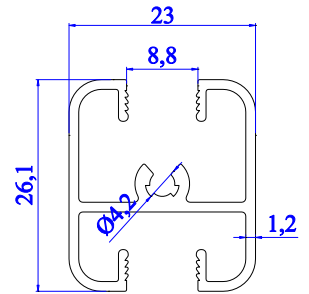

3998 - 0.385 kg/m

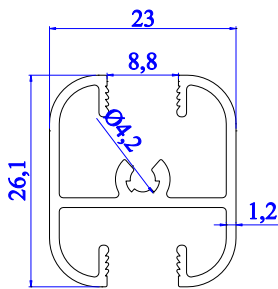

4004 - 0.374 kg/m

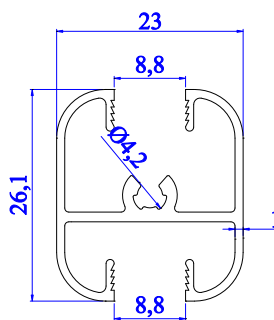

5153 - 0.329 kg/m

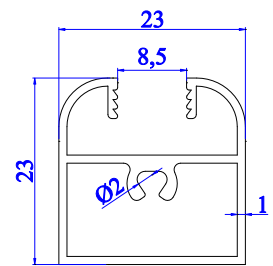

4928 - 0.324 kg/m

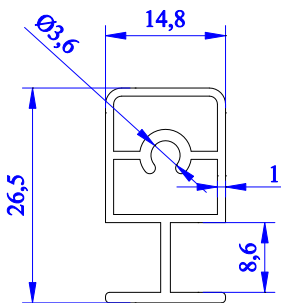

4887 - 0.299 kg/m

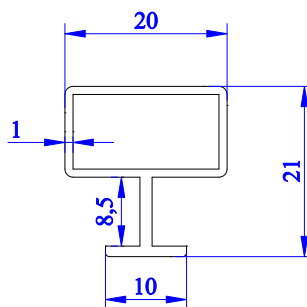

5427 - 0.225 kg/m

ALÜMİNYUM SÜPÜRGELİK PROFİLLERİ

Aluminium Baseboards Profiles

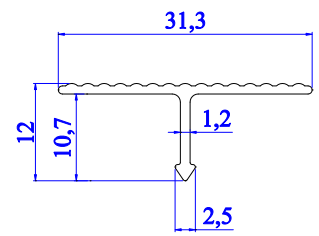

3990 - 0.135 kg/m

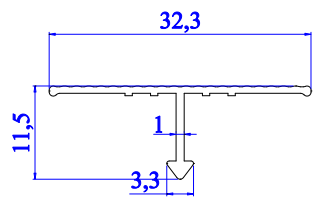

4860 - 0.121 kg/m

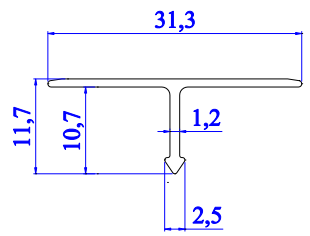

3989 - 0.122 kg/m

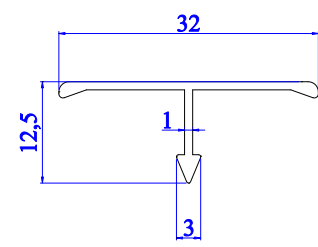

4861 - 0.134 kg/m

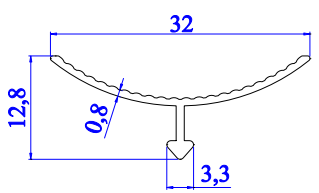

4858 - 0.110 kg/m

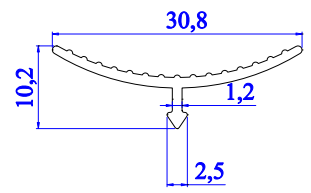

3992 - 0.129 kg/m

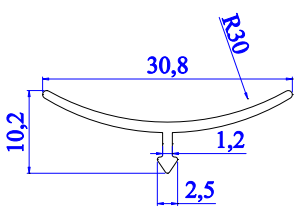

3991 - 0.122 kg/m

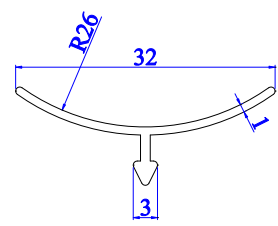

4857 - 0.119 kg/m

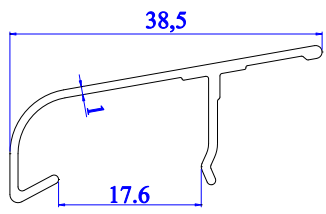

3993 - 0.203 kg/m

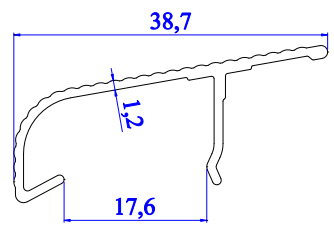

3994 - 0.217 kg/m

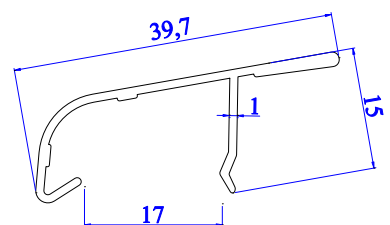

4854 - 0.201 kg/m

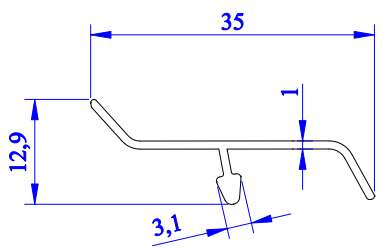

5317 - 0.141 kg/m

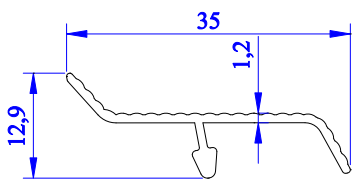

5387 - 0.152 kg/m

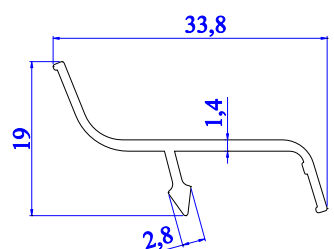

4856 - 0.183 kg/m

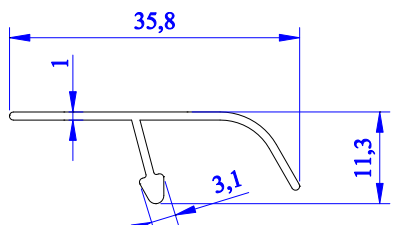

5318 - 0.143 kg/m

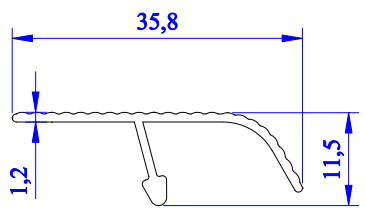

5388 - 0.160 kg/m

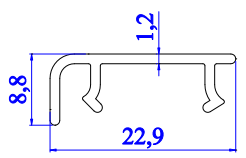

4914 - 0.138 kg/m

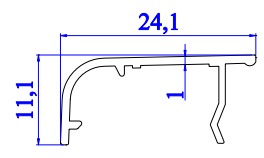

5185 - 0.117 kg/m

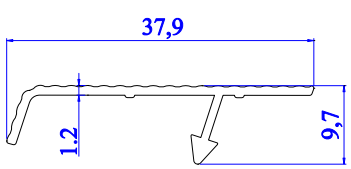

4952 - 0.161 kg/m

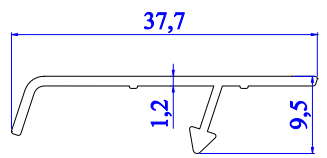

4855 - 0.169 kg/m

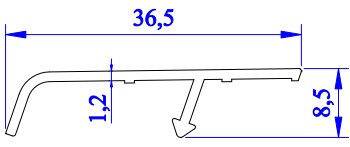

5183 - 0.162 kg/m

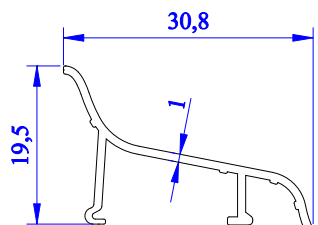

5437 - 0.166 kg/m

ALÜMİNYUM ZEMİN PROFİLLERİ

Aluminium Ground Profiles

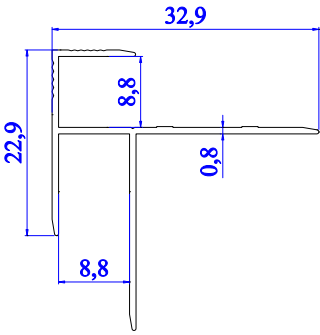

5000 - 0.187 kg/m

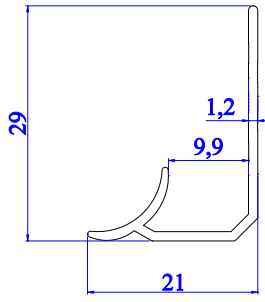

2940 - 0.170 kg/m

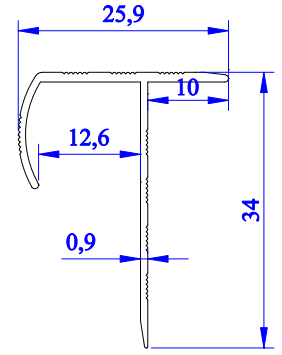

5542 - 0.181 kg/m

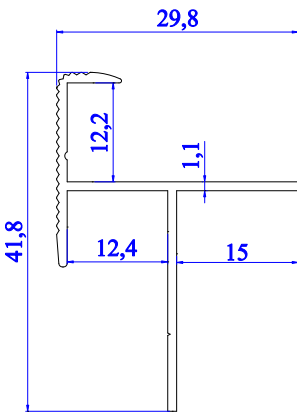

4654 - 0.256 kg/m

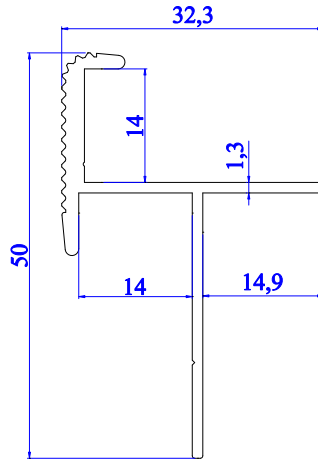

3550 - 0.391 kg/m

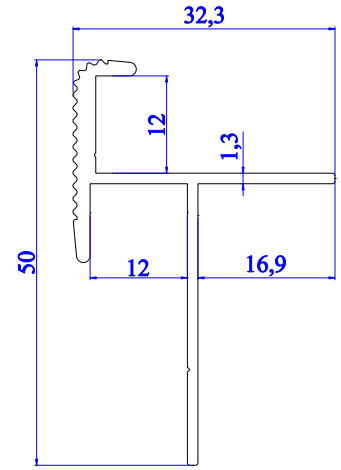

3551 - 0.394 kg/m

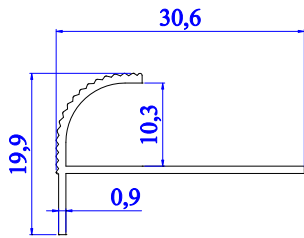

4653 - 0.120 kg/m

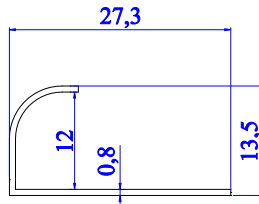

4649 - 0.092 kg/m

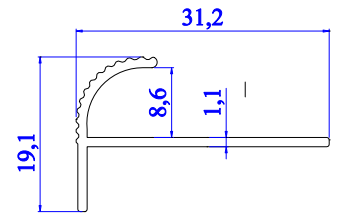

3552 - 0.171 kg/m

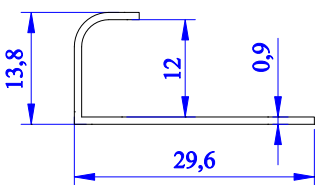

5543 - 0.117 kg/m

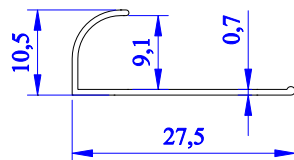

3780 - 0.078 kg/m

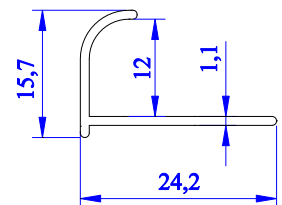

5545 - 0.125 kg/m

ALÜMİNYUM ZEMİN PROFİLLERİ

Aluminium Ground Profiles

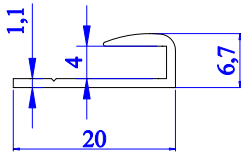

5559 - 0.100 kg/m

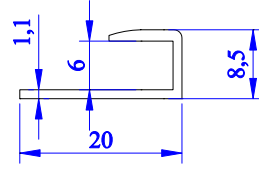

1374 - 0.108 kg/m

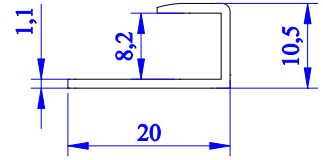

4329 - 0.111 kg/m

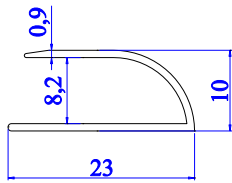

5002 - 0.114 kg/m

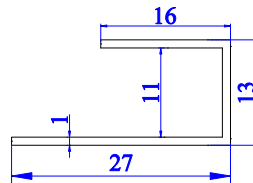

5044 - 0.146 kg/m

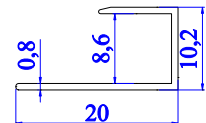

5001 - 0.081 kg/m

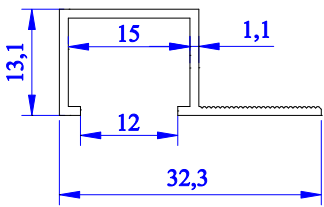

5546 - 0.173 kg/m

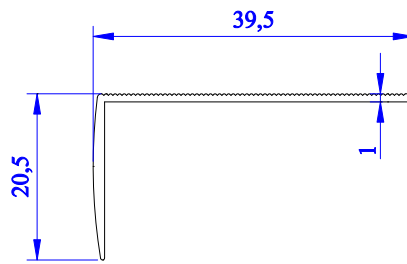

5544 - 0.159 kg/m

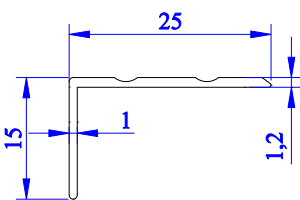

5547 - 0.111 kg/m

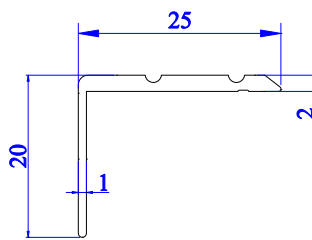

2939 - 0.171 kg/m

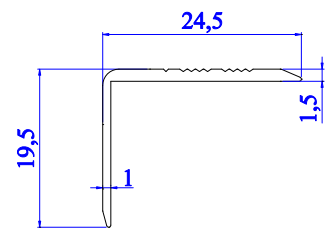

4651 - 0.137 kg/m

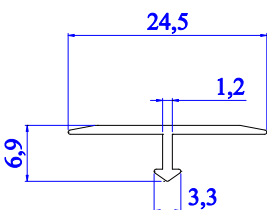

4650 - 0.090 kg/m

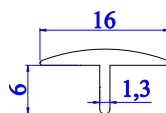

4688 - 0.085 kg/m

ALÜMİNYUM ZEMİN PROFİLLERİ

Aluminium Ground Profiles

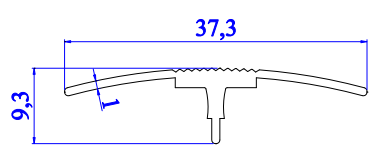

4652 - 0.163 kg/m

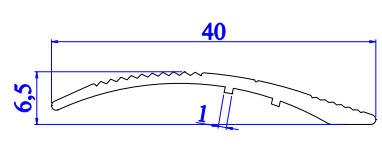

2942 - 0.174 kg/m

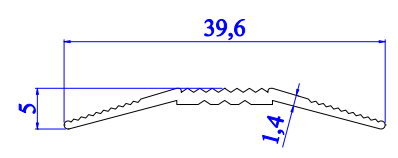

2941 - 0.138 kg/m

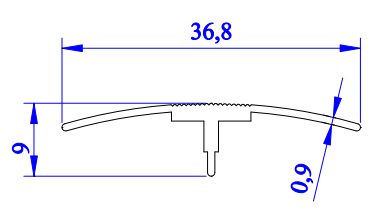

5548 - 0.146 kg/m

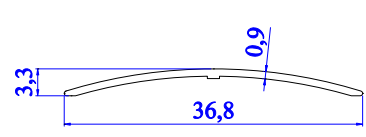

4954 - 0.089 kg/m

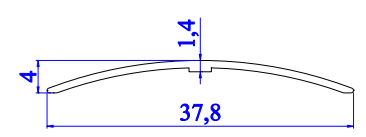

4953 - 0.095 kg/m

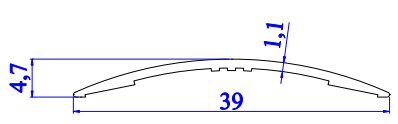

4998 - 0.124 kg/m

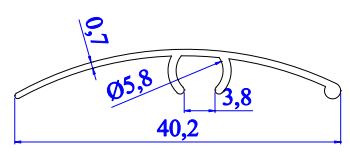

4017 - 0.121 kg/m

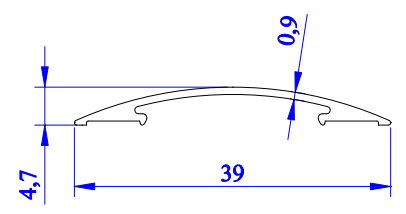

5520 - 0.130 kg/m

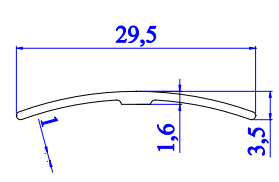

5281 - 0.087 kg/m

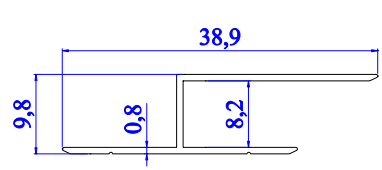

4999 - 0.133 kg/m

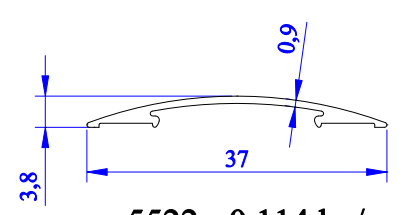

5522 - 0.114 kg/m

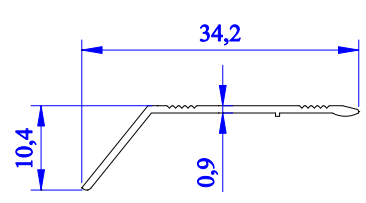

5521 - 0.093 kg/m

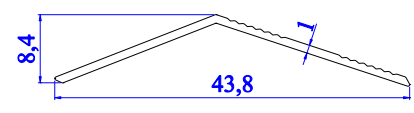

5003 - 0.192 kg/m

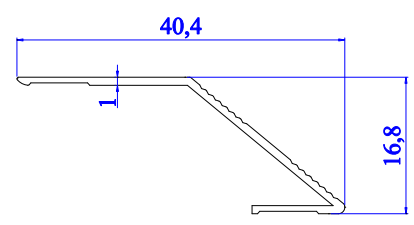

5523 - 0.136 kg/m

ALÜMİNYUM RAF VE ASKI PROFİLLERİ

Aluminium Shelf and Hook Profiles

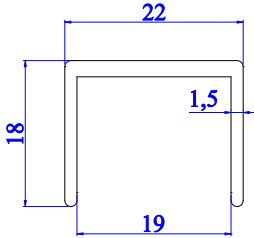

4287 - 0.246 kg/m

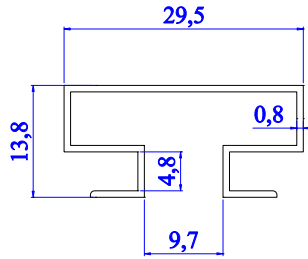

4293 - 0.184 kg/m

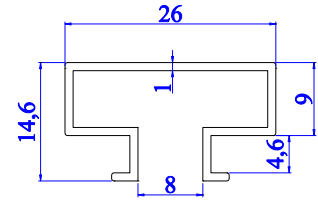

4921 - 0.198 kg/m

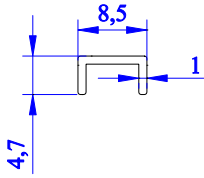

4127 - 0.043 kg/m

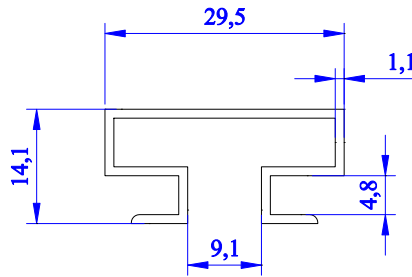

1818 - 0.253 kg/m

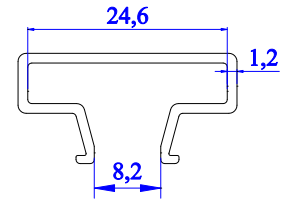

5182 - 0.216 kg/m

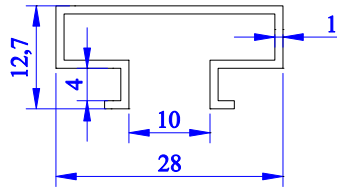

2149 - 0.195 kg/m

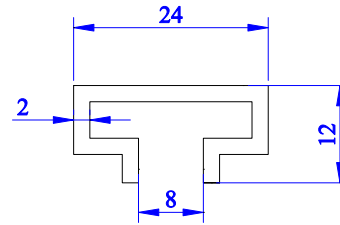

1761 - 0.304 kg/m

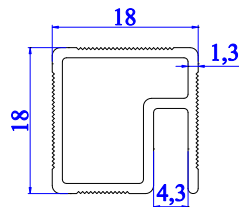

4833 - 0.246 kg/m

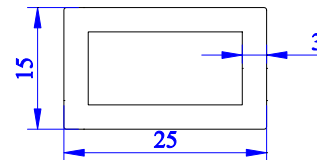

4896 - 0.551 kg/m

ALÜMİNYUM RAF VE ASKI PROFİLLERİ

Aluminium Shelf and Hook Profiles

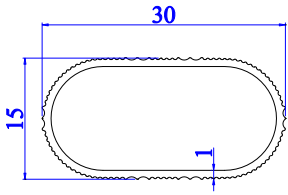

4852 - 0.185 kg/m

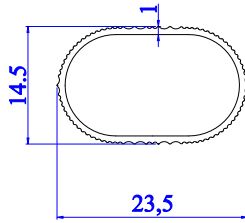

4917 - 0.126 kg/m

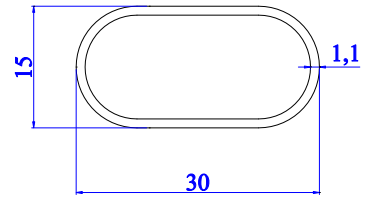

5268 - 0,219 kg/m

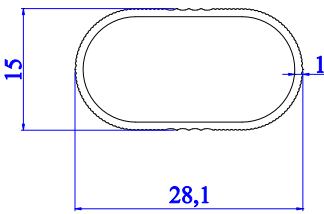

5114 - 0.178 kg/m

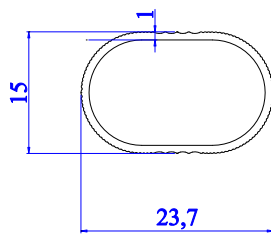

5115 - 0.157 kg/m

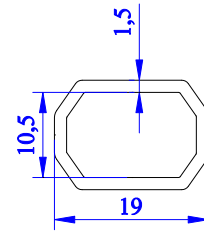

5166 - 0.211 kg/m

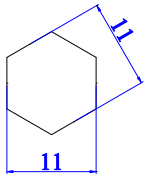

1066 - 0.284 kg/m

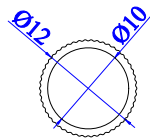

4825 - 0.085 kg/m

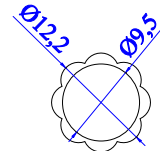

4831 - 0.096 kg/m

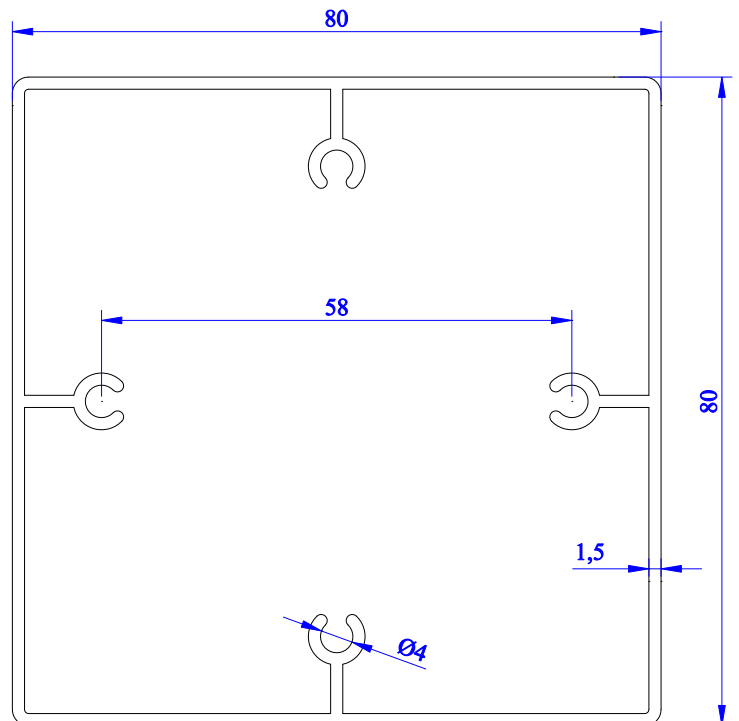

5456 - 1.591 kg/m

ALÜMİNYUM RAF VE ASKI PROFİLLERİ

Aluminium Shelf and Hook Profiles

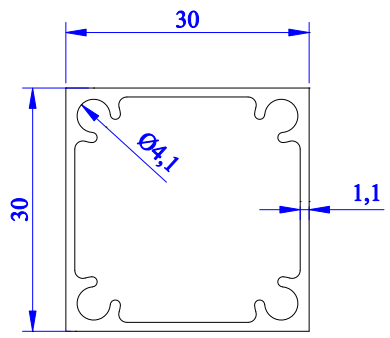

2822 - 0.456 kg/m

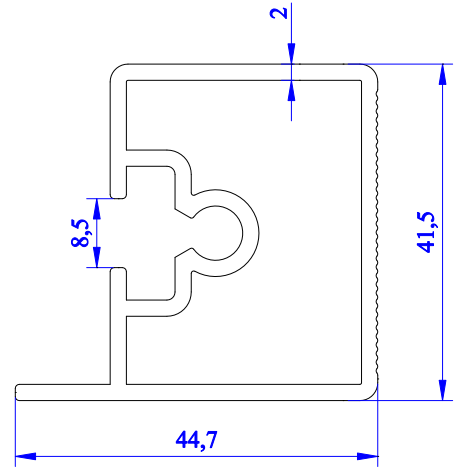

5264 - 1,010 kg/m

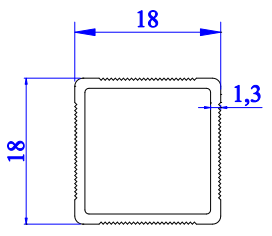

4832 - 0.208 kg/m

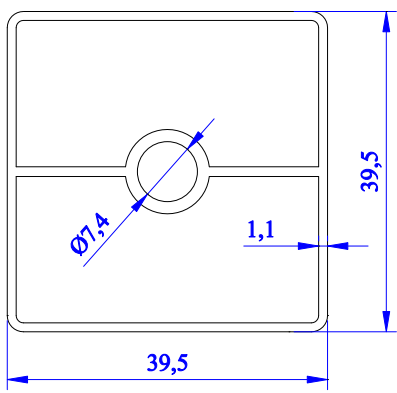

5382 - 0,649 kg/m

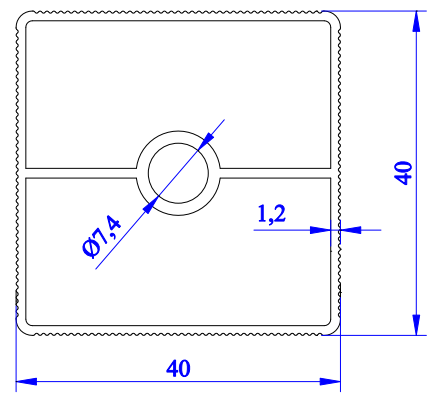

5383 - 0,646 kg/m

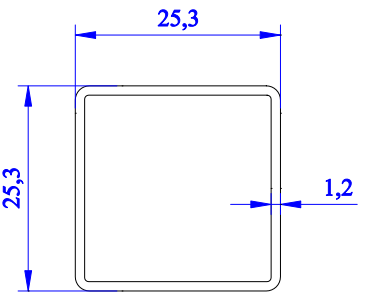

1806 - 0.295 kg/m

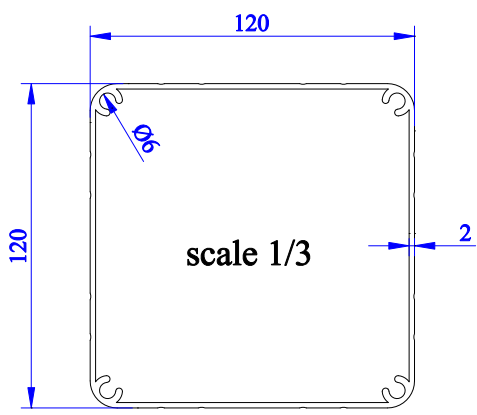

4202 - 2.783 kg/m

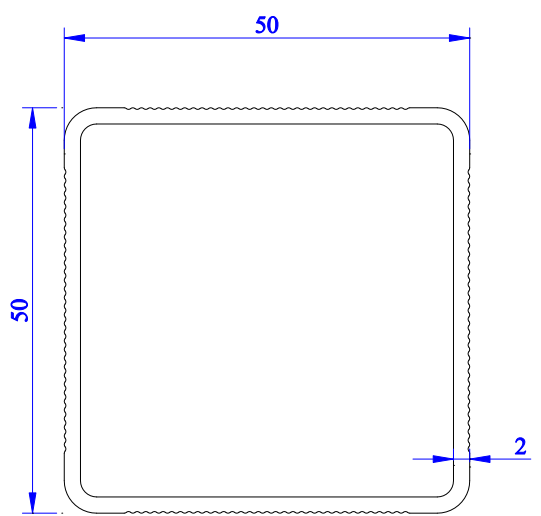

5265 - 0.972 kg/m

ALÜMİNYUM RAF VE ASKI PROFİLLERİ

Aluminium Shelf and Hook Profiles

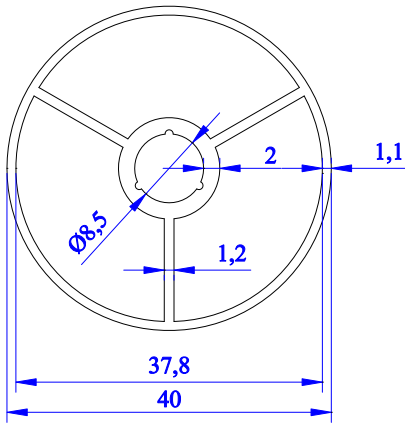

5252 - 0.661 kg/m

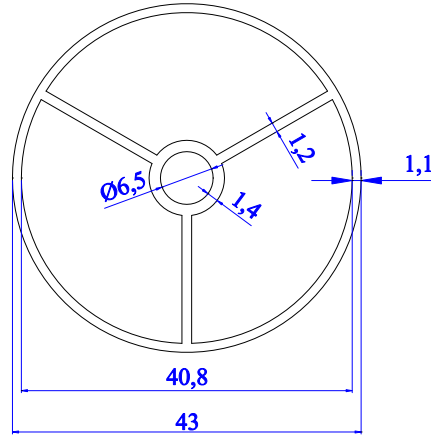

4907 - 0.637 kg/m

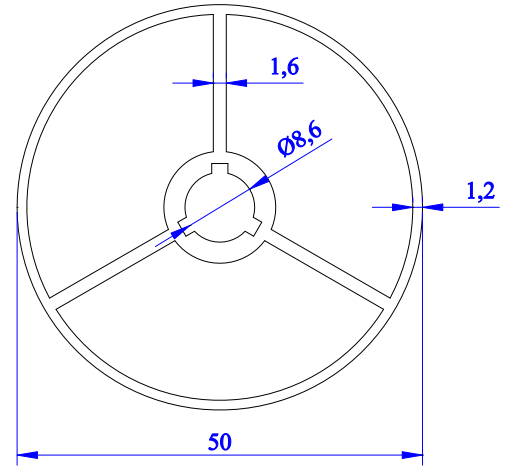

5266 - 0,945 kg/m

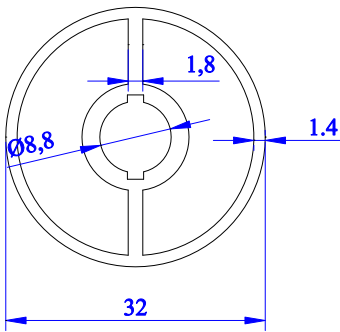

5267 - 0,637 kg/m

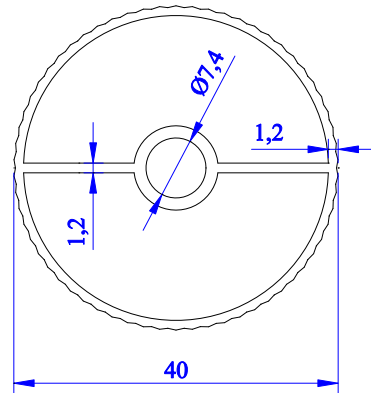

5496 - 0,561 kg/m

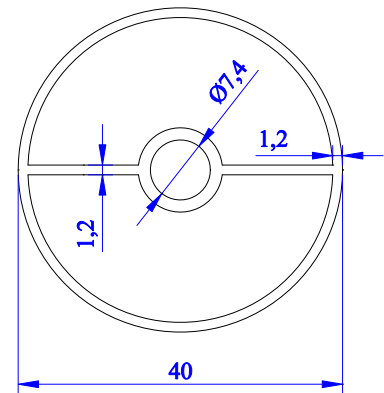

5497 - 0,596 kg/m

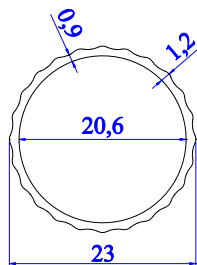

4537 - 0.190 kg/m

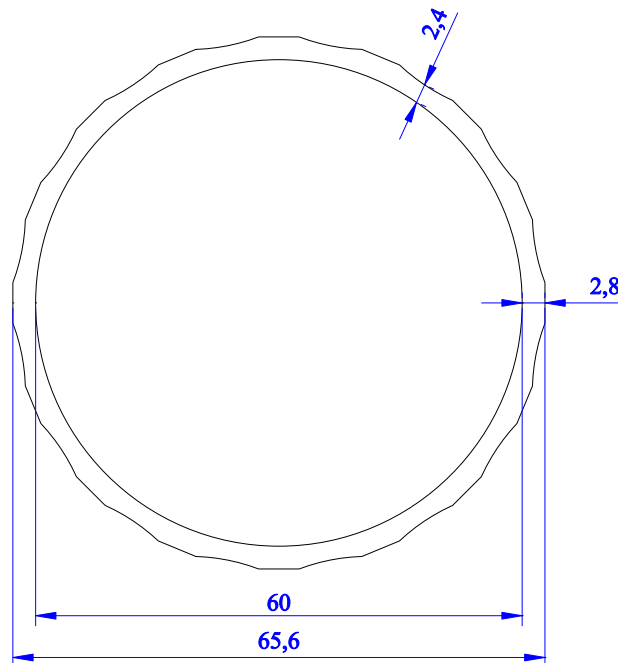

3506 - 1,413 kg/m

ALÜMİNYUM RAF VE ASKI PROFİLLERİ

Aluminium Shelf and Hook Profiles

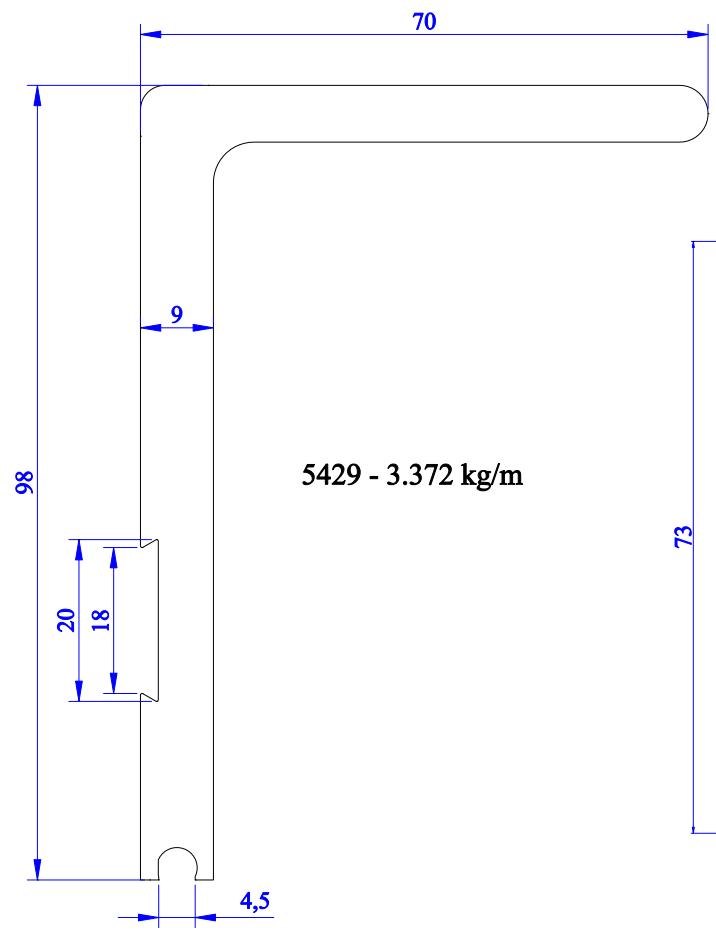

5429 - 3.372 kg/m

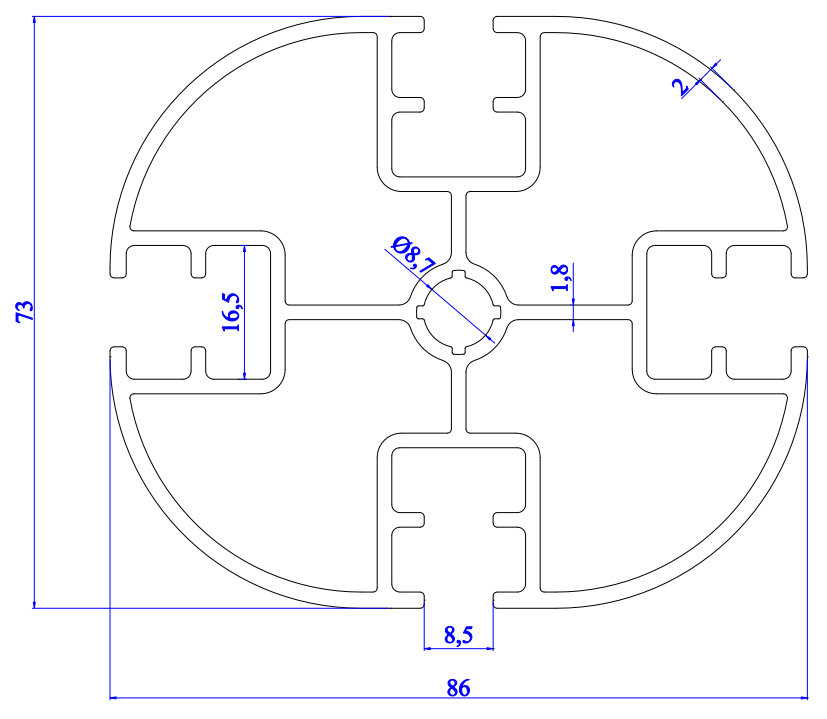

4978 - 2.795 kg/m

ALÜMİNYUM RAF VE ASKI PROFİLLERİ

Aluminium Shelf and Hook Profiles

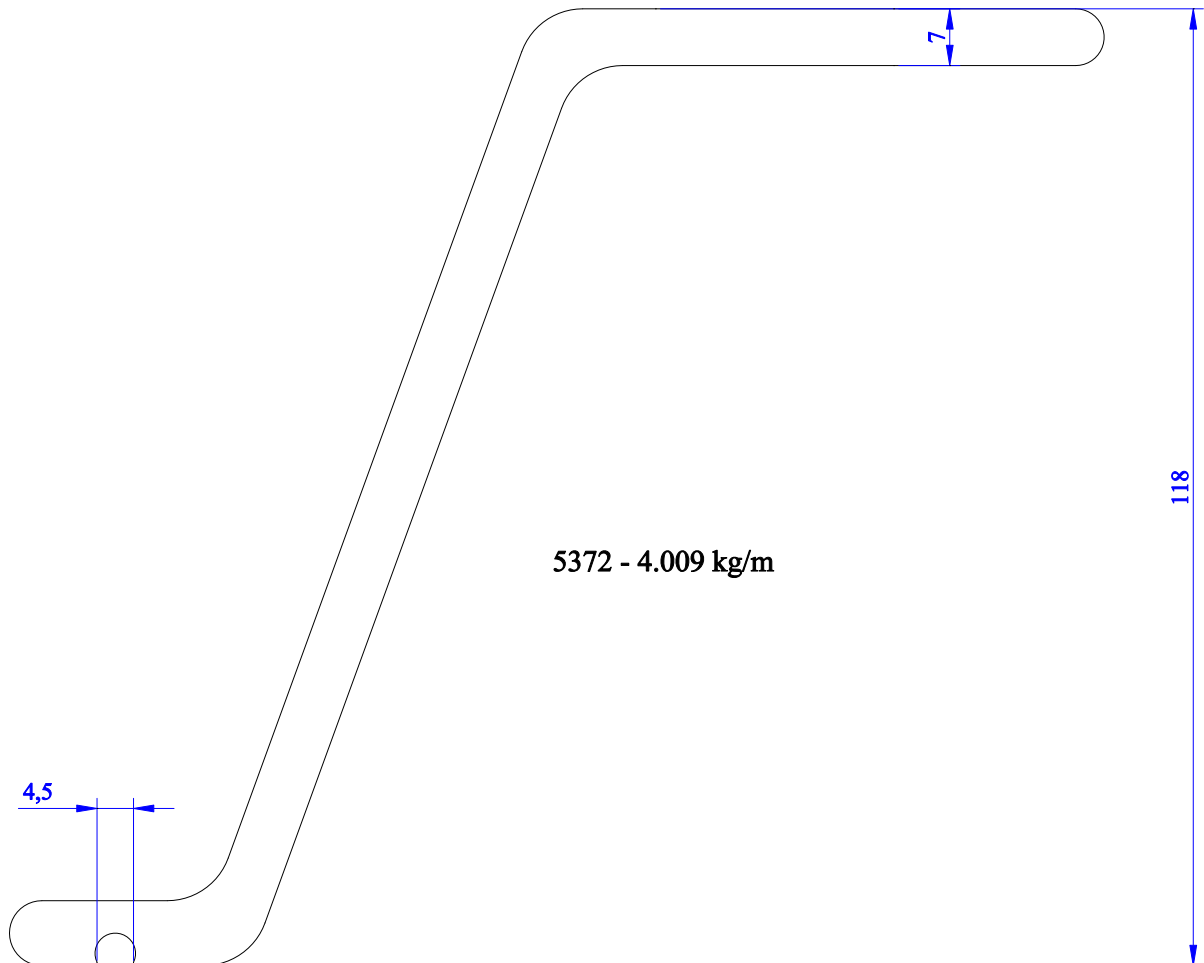
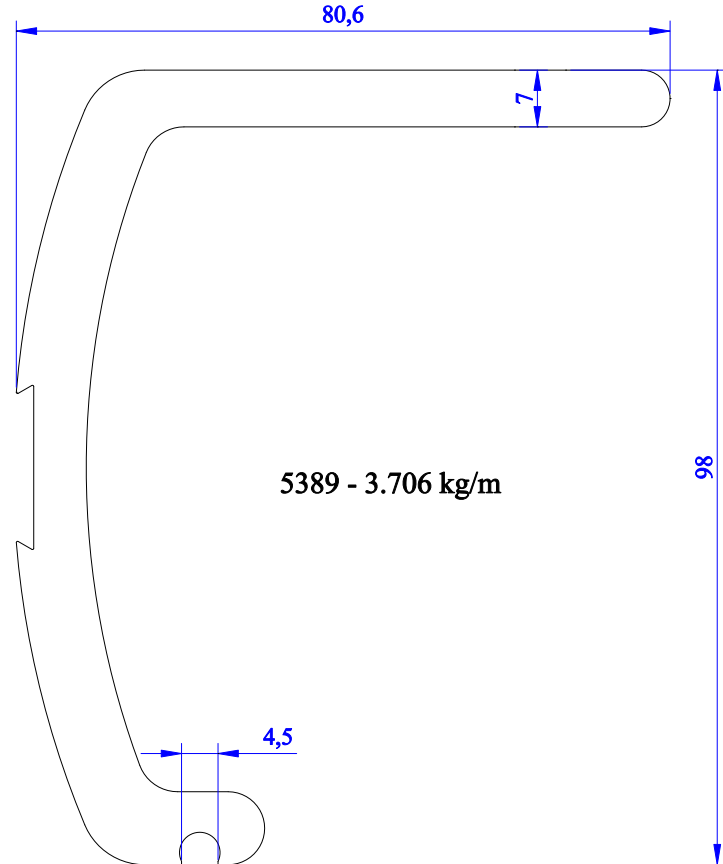
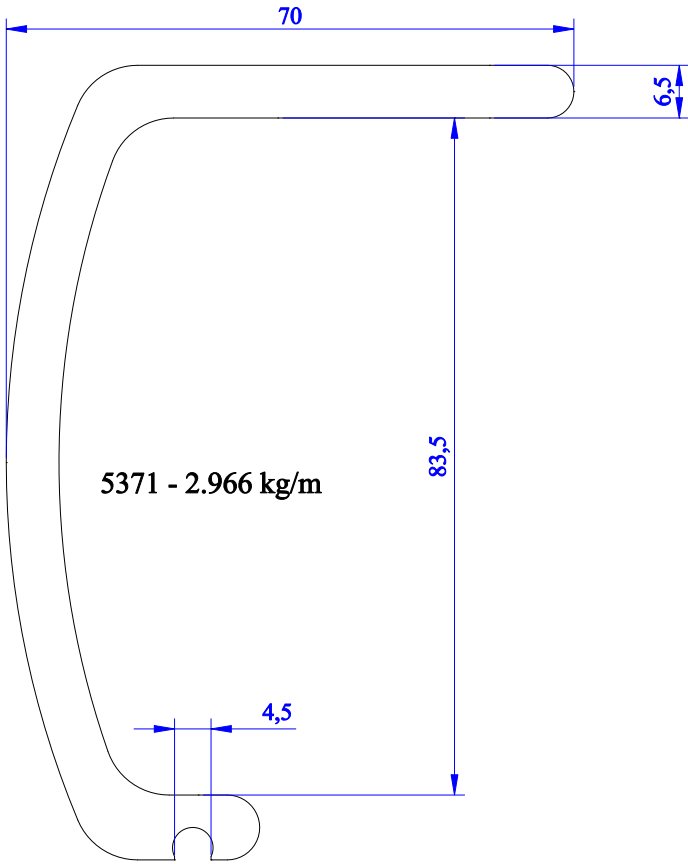

STANDART PROFILLER / STANDART PROFILES

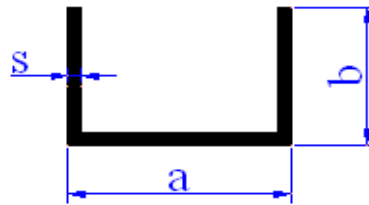

U PROFILLER				
PROFILNO:	a	b	s	Kg/m
5434	6,5	10,5	1	0,069
5572	8,7	10	1,1	0,079
1268	11,5	12	2,00	0,171
1983	12	16	1,10	0,124
4909	12,2	20	2,00	0,260
1890	13	17	1,00	0,123
1666	17	14,5	1,00	0,119
1634	17	16	1,00	0,127
1246	17	17	1,50	0,195
1341	18	20	1,00	0,152
5361	18	20	1,25	0,187
1195	18,5	13	1,20	0,137
1344	19	20	1,15	0,177
1245	19	20	1,50	0,224
1431	20	25	1,40	0,255
4289	20,4	18	1,00	0,147
4658	20,8	8	1,20	0,110
4434	21	20	1,00	0,160
1247	21	25	1,50	0,276
4140	23,2	16,1	1,10	0,159
2177	26,5	30	2,00	0,447
1140	30	20	1,00	0,184
4631	30	15	1,10	0,172
1128	65	10	1,50	0,333
2161	79	30	2,00	0,732

STANDART PROFILLER / STANDART PROFILES

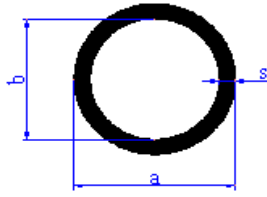

BORU PROFILLER				
PROFİL NO	a	b	s	Kg/m
3896	7	5	1	0,051
4766	8	6	1	0,060
3734	9,3	4	2,65	0,150
5384	9,7	7,7	1	0,074
4669	10	3,5	3,25	0,185
4100	10	5	2,5	0,160
5159	10	8	1	0,077
5451	12	9,2	1,4	0,126
4130	12	10	1	0,093
5163	12	10,15	0,93	0,086
2160	13	11	1	0,102
1172	15	10	2,5	0,264
4399	15,5	13,5	1	0,123
3686	15,8	12,2	1,8	0,215
2995	16	4,5	5,75	0,500
2156	16	7,5	4,25	0,425
4465	16	8	4	0,408
2159	16	12,2	1,9	0,228
5133	16	13,5	1,25	0,157
4141	16	14	1	0,128
2122	19	16,2	1,4	0,210
2158	19	16,3	1,35	0,203
4692	19	16,6	1,2	0,181
2994	19,2	16,6	1,3	0,219
4264	19,5	7	6,25	0,705
2102	19,8	17	1,4	0,219
4099	20	14	3	0,434
4875	20	15,5	2,25	0,339
1089	20	17,5	1,25	0,200
2116	20	17,7	1,15	0,184
4680	20	18	1	0,160
3749	21,5	19	1,25	0,216
4046	21,6	18,8	1,4	0,241
3603	22	5	8,5	0,977
1160	22	20	1	0,179
2147	23	20	1,5	0,275
2101	23	20,2	1,4	0,257
4536	23	21	1	0,187
4974	24	12	6	0,916
4758	24	18	3	0,534
4403	24,5	17,5	3,5	0,625
1042	25	10	7,5	1,117
1048	25	20	2,5	0,480
1288	25	22	1,5	0,298
2109	25	23	1	0,204
2157	26	10	8	1,226
1596	27	25	1	0,221
3748	27,5	24,8	1,35	0,301
1406	28	22	3	0,639
3970	28	26	1	0,230

BORU PROFILLER				
PROFİL NO	a	b	s	Kg/m
1565	29,5	25	2,25	0,522
2926	30	9,1	10,45	1,739
3094	30	14	8	1,493
3838	30	16,1	6,95	1,364
3747	30	20,2	4,9	1,047
1302	30	25	2,5	0,583
4096	30	26	2	0,477
1178	30	28	1	0,245
5390	32	29,8	1,1	0,288
4327	33,7	30,5	1,6	0,437
4693	35	29	3	0,814
4915	35	30	2,5	0,689
4238	35	31,8	1,6	0,455
3729	36,5	34,1	1,2	0,361
1377	39	37	1	0,324
4097	40	30	5	1,490
4615	40	35	2,5	0,795
4691	40	36	2	0,644
4532	40	37	1,5	0,490
5170	40	37,6	1,2	0,395
4101	40,5	37,5	1,5	0,498
1263	44	40	2	0,178
4326	44	40,8	1,6	0,576
3505	45	20,3	12,35	3,450
4119	45	40	2,5	0,905
4667	45	43	1	0,373
3093	50	42	4	1,561
1807	50	44	3	1,196
2993	50	45,2	2,4	0,970
4098	50	46	2	0,817
3872	50	46,8	1,6	0,659
2066	50	47,2	1,4	0,575
2117	50	47,4	1,3	0,539
2990	53,6	50,4	1,6	0,708
2998	55	50,4	2,3	1,030
1616	57	55	1	0,460
4610	60	20	20	6,785
2988	60	20,3	19,85	6,761
5117	60	55,2	2,4	1,173
5169	60	57,6	1,2	0,599
5515	60	58	1	0,501
3837	60,4	30,2	15,15	5,734
4073	63,5	59,5	2	1,047
3836	70,4	40,7	14,85	7,007
5294	72	68	2	1,188
1134	73	66	3,5	2,064
3867	80	75,7	2,15	1,420
3835	80,4	50,2	15,15	8,280
3866	92	75	8,5	6,020

STANDART PROFİLLER / STANDART PROFILES



BORU ÇUBUKLAR		
PROFİL NO	a	Kg/m
1275	6	0,077
5293	6,9	0,101
1250	8,5	0,154
1466	9	0,172
1301	10	0,213
4668	12	0,305
1251	13	0,360
4077	16,1	0,552
1409	18	0,690
3758	20	0,851
2152	23	1,122
2352	25	1,330
2353	30	1,916
1044	41	3,578
4573	45	4,300
1045	51	5,536
4682	57	6,890
1046	61	7,920
4681	67	9,520
1047	71	10,729
3504	80	13,622

STANDART PROFİLLER / STANDART PROFILES

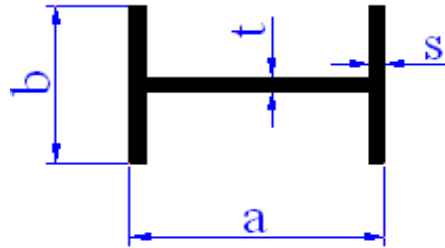

H PROFİLLER					
PROFIL NO	a	b	s	t	Kg/m
1092	20	32	1	3	0,320
1117	56,5	21	2	2	0,510
1063	57	22	2	2	0,525
1064	68	22	2	2	0,585
1116	68,5	22	2	1,8	0,553
1065	75	22	2,5	2,5	0,772

STANDART PROFİLLER / STANDART PROFILES



KARE ÇUBUKLAR		
PROFİL NO	a	Kg/m
1463	5	0,068
1727	8	0,173
1133	10	0,271

STANDART PROFİLLER / STANDART PROFILES

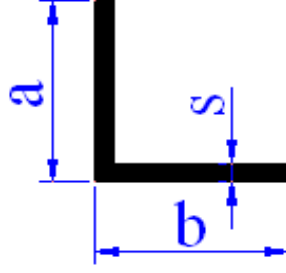

KÖŞEBENT PROFİLLER				
PROFİL NO	a	b	s	Kg/m
1291	10	10	1,1	0,056
1292	15	10	1,2	0,077
1021	15	15	1,6	0,123
3821	16,3	14	7	0,442
1295	20	10	1,5	0,116
5175	20	15	1,3	0,119
1400	20	15	4	0,336
1650	20	20	1	0,106
5477	20	20	1,8	0,186
1298	20	20	1,5	0,163
3859	22	14	2,4	0,219
5332	22	22	1,8	0,205
3858	24,5	24,5	2,4	0,300
4205	25	8	1	0,087
1243	25	10	2	0,178
1323	25	15	3	0,300
5178	25	20,2	1,15	0,138
1637	25	25	1	0,133
1297	25	25	1,5	0,197
1240	25	25	2	0,260
1322	25	25	2,7	0,346
4767	25,1	21,1	8	0,824
3542	30	10	1,2	0,126
1040	30	11,5	1,4	0,152
5004	30	15	1	0,119
4268	30	15	1,1	0,131
4466	30	15	2	0,233
5005	30	20	1	0,133
4300	30	20	1,2	0,159
1636	30	30	1	0,160
1242	30	30	2,5	0,390
1149	30	30	3	0,461
3668	30	30	4	0,605

KÖŞEBENT PROFİLLER				
PROFİL NO	a	b	s	Kg/m
1763	35,5	6	1,5	0,163
4612	36,9	15,2	1,2	0,165
1638	40	20	1	0,160
1293	40	20	1,6	0,253
1241	40	20	2	0,313
1050	40	20	4	0,620
4690	40	30	1,1	0,204
4145	40	30	3	0,543
2400	40	40	1,5	0,319
1296	40	40	2	0,420
1465	40	40	3	0,626
4540	40	40	4	0,820
1361	40	40	4	0,820
5179	40,5	18,5	1,8	0,278
1148	45	30	4	0,766
5287	45	45	2	0,475
4820	45	45	2	0,475
1771	50	20	1	0,187
4063	50	30	5	1,016
3085	50	50	3	0,786
1403	50	50	4	1,040
4064	50	50	5	1,287
1194	60	10	2,2	0,404
1412	60	20	1	0,213
4065	60	60	6	1,854
5174	70	18	1,5	0,351
3571	80	20	1,5	0,400
5286	80	50	3,15	1,079
4066	80	80	8	3,295
3670	100	100	10	5,130
5285	150	60	3,15	1,761
5552	180	60	4	2,550

STANDART PROFİLLER / STANDART PROFILES

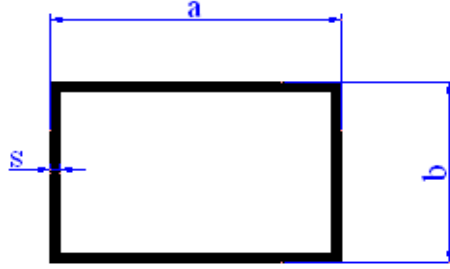

KUTU PROFİLLER				
PROFİL NO	a	b	s	Kg/m
3557	10	10	1,80	0,155
3772	14	14	0,80	0,114
1022	15	15	1,00	0,152
1168	18	14	1,00	0,163
4313	18	18	1,20	0,219
1765	19,9	19,9	1,05	0,214
1138	20	20	1,20	0,244
5036	20	20	1,50	0,300
1568	23,5	19	1,60	0,341
4896	25	15	3,00	0,551
1642	25	17	1,00	0,216
1595	25	17	1,30	0,276
5549	25	25	1,50	0,381
3576	25	25	2,50	0,608
1806	25,3	25,3	1,15	0,295
1599	29	29	1,00	0,304
1325	30	10	1,50	0,299
1030	30	20	1,00	0,260
1733	30	20	1,00	0,260
1598	30	30	1,00	0,313
1651	40	20	1,00	0,314
1652	40	20	1,20	0,373
4325	40	20	1,40	0,434
5502	40	20	2,00	0,605
2003	40	40	1,00	0,420
4932	40	40	1,20	0,502
1276	40	40	1,50	0,626
5037	40	40	2,00	0,821
2153	40	40	2,50	1,013

KUTU PROFİLLER				
PROFİL NO	a	b	s	Kg/m
4074	43	18	1,00	0,320
5219	44	27,5	1,20	0,448
4235	45	30	1,00	0,396
4129	50	30	1,50	0,626
2004	50	40	1,00	0,485
4118	50	40	2,00	0,932
4565	50	50	1,50	0,786
5516	50	50	2,00	1,037
2197	60	20	1,10	0,467
2006	60	40	1,50	0,790
2018	60	40	1,80	0,937
4078	60	60	1,30	0,951
2017	60	60	1,50	0,951
4131	64	24	0,70	0,331
2000	70	30	1,00	0,531
2002	75	32	1,10	0,625
4047	80	20	1,30	0,688
2015	80	40	1,50	0,951
5501	80	40	2,00	1,253
4282	80	65	1,65	1,269
5503	80	80	2,00	1,680
2010	90	50	1,40	1,041
2011	95	50	1,50	1,154
4427	100	20	1,30	0,825
4226	100	25	1,60	1,057
4281	100	65	1,80	1,584
2012	120	60	1,80	1,721
4201	120	65	2,00	1,955

STANDART PROFİLLER / STANDART PROFILES

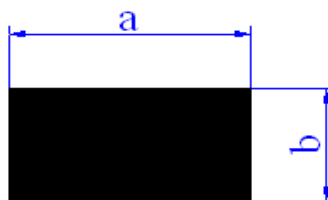

LAMA PROFİLLER				LAMA PROFİLLER			
PROFİL NO	a	b	Kg/m	PROFİL NO	a	b	Kg/m
4679	13	3	0,105	1741	40	6	0,650
5045	15	2,5	0,101	1035	40	10	1,084
3914	15	5	0,203	4609	40	30	3,240
1032	16	2	0,087	1098	42	10	1,138
1368	16	3	0,130	4391	45	10	1,215
5113	16,9	10	0,456	1036	50	10	1,355
1103	18	5,5	0,268	1387	52	2,5	0,352
3860	19,5	4,5	0,238	4144	53	7,9	1,145
1115	20	5	0,271	1392	57	2,5	0,386
1020	20	10	0,542	1386	58	1,5	0,236
1248	21,5	5,5	0,320	4520	60	3,6	0,583
1024	25	2,5	0,168	1034	60	10	1,626
1200	25	8,5	0,576	4829	80	1,5	0,324
1033	30	3	0,244	1071	90	3	0,731
4584	30	10	0,814	5519	95	1,5	0,385
4146	30	10	0,813	5448	100	1,5	0,405
4502	30	20	1,620	4227	100	2	0,542
1031	35	5	0,474	1043	100	10	2,710
4586	36	1,2	0,117	5449	150	1,5	0,608
5447	40	1,5	0,162	5450	200	2	1,080
2201	40	4	0,432	3895	200	20	10,800

STANDART PROFİLLER / STANDART PROFILES

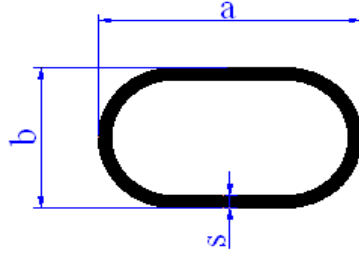

RADÜSLÜ KUTU PROFİLLER				
PROFİL NO	a	b	s	Kg/m
1337	25	10	1,5	0,250
1170	27	14	0,85	0,155
2552	27	15	1,45	0,262
5268	30	15	1,1	0,219
1533	38	20,5	1,05	0,284
1532	55	24,2	1	0,364
2550	85,4	54,4	11,7	6,219

STANDART PROFİLLER / STANDART PROFILES

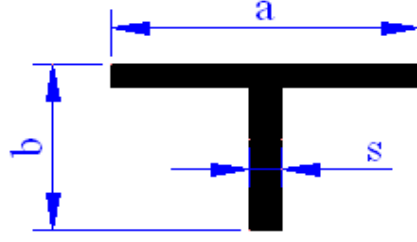

PROFİL NO	T PROFİLLER			Kg/m
	a	b	s	
1329	15	15	1,5	0,116
1330	20	20	1,5	0,157
1649	25	25	1,1	0,146
1331	25	25	2	0,260
1383	25	25	4	0,499
1332	25	30	1,5	0,217
2606	30	10	1,1	0,116
5047	30	17	1	0,124
1639	30	30	1,1	0,176
1462	30	30	2	0,314
1418	35	25	2,2	0,346
1023	50	50	5	1,287
5290	50	70	2,5	0,793
5289	70	50	2,5	0,793